



**The Accessibility for Manitobans Act (AMA)**

**Discussion Paper on a  
Proposed Accessibility Standard  
For the Design of Public Spaces**

---

**December 11, 2019  
Winnipeg, MB**

The Accessibility Advisory Council (Council) is pleased to present its draft Accessibility Standard on the Design of Public Spaces for public feedback in accordance with [The Accessibility for Manitobans Act \(AMA\)](#).

In March 2019, the Honourable Heather Stefanson, Minister responsible for the AMA, established the [Terms of Reference](#) for the Design of Public Spaces Accessibility Standard. The Minister requested that the standard specify requirements to identify, prevent and remove barriers in the design of exterior public spaces. In this way, the Design of Public Spaces Accessibility Standard aims to address only those areas outside the jurisdiction of The Manitoba Building Code. Enhancement of accessibility through updates to the Manitoba Building Code will take place through a separate process, apart from the work performed under the AMA.

The Council has the responsibility to make recommendations to the Minister regarding the development of accessibility standards. The Council is composed of up to nine members with diverse backgrounds and experience, including representatives of organizations of persons with disabilities, business, municipalities and other organizations.

Under the AMA, the Council has the authority to establish standard development committees with the expertise required to develop a particular standard. The Council created a Design of Public Spaces Standard Development Committee and selected its members with approval from the Deputy Minister of Families.

The Committee, which represents a broad range of interests, met 20 times between November 2018 and September 2019. It submitted its report on September 30, 2019, when the Council began its review of the proposed Standard. The minimum requirements presented herein represent a consensus of the Committee and will be further refined by public input. The Council extends its gratitude to Glen Manning, chairperson, and the [members of the Standard Development Committee on the Design of Public Spaces](#); Steven Spry (co-Chairperson), John Wyndels, Bob Somers, Colin Marnoch, Kris Cowley, Rebecca Luhn-Jensen, Norman Garcia, Shauna Prociuk, Jackie Wilkie.

## 1. Social and Legal Framework

The AMA became law in 2013. The purpose of the legislation is to provide a clear and proactive process for the identification, prevention and removal of barriers. Accessibility standards under the AMA are laws that in Manitoba affect businesses and organizations. The AMA identifies five fundamental areas for standard development: customer service, employment, information and communications, transportation and the built environment.

Standards provide a legally binding foundation for practice and enforcement. Standards are in force for accessible building design in the form of the Manitoba Building Code, but the design of accessible exterior environments is governed only by non-binding guidance documents in Manitoba. The enactment of the Design of Public Spaces Standard will therefore fill a significant gap.

The social and legal rationale for the AMA can be summarized as follows:

- Accessibility will improve the health, independence and well-being of persons disabled by barriers.
- Barriers create considerable costs to persons disabled by those barriers, their families and friends, and to communities and the economy.
- In developing our built environment, barriers have been perpetuated.
- A systemic and proactive approach for identifying, preventing and removing barriers complements The Human Rights Code (Manitoba) in ensuring accessibility for Manitobans.
- Under The United Nations Convention on the Rights of Persons with Disabilities, which Canada ratified in 2010, member states are expected to take appropriate measures to ensure accessibility and independent living.
- The equality rights of all Canadians, including persons disabled by barriers, are enshrined in the Canadian Charter of Rights and Freedoms.

If we want everyone to participate in public life, we must design and build inclusive public spaces that are accessible to all. Everyone accesses the built environment differently, with abilities changing across a person's lifespan. With an estimated one in four Manitobans affected by disability, and

that number expected to increase in the years ahead, we must design and build public spaces that are accessible to all.

Barriers are often created and perpetuated through a lack of planning or appreciation of the significance these obstacles play in people's daily lives. A proactive process of developing accessibility standards for public spaces and regularly updating them will help designers, developers and administrators to create more inclusive communities and benefit all Manitobans, regardless of abilities.

## **2. Scope and Intent**

The Design of Public Spaces document includes the process of planning, organization, and construction of the exterior built environment affecting the exterior environment, along with the maintenance of these spaces. Public spaces covered by this standard include, but are not limited to:

- Pedestrian routes and signal systems
- Parking areas
- Recreational trails and beach access routes
- Outdoor plazas and public eating areas
- Outdoor parks, play structures, and other community spaces

The Accessibility Standard for the Design of Public Spaces aims to identify, prevent and remove barriers to public outdoor spaces by providing specific minimum requirements. It is not intended to limit the creativity of the design process during planning, construction and maintenance of public infrastructure.

Whether it be safer streetscapes, a re-thinking of bike lanes, or a broader approach to designing communities for people of all ages and abilities, jurisdictions are being challenged to meet the changing needs of its citizens. Just as there is no shortage of publications advancing the need for greater accessibility in our exterior environments, there currently exists any number of design standards for the exterior environment, including Ontario's Design of Public Spaces Accessibility Standard. It is one of several source materials utilized by the committee in determining the technical requirements of the draft Standard. For a complete list of the source materials used, see [Appendix 1](#).

### 3. Moving Forward

The Council welcomes your feedback on its draft accessibility standard on the Design of Public Spaces. You are invited to prepare written submissions and briefs in response to the draft standard presented below.

#### **Disabilities Issues Office**

630 - 240 Graham Avenue

Winnipeg MB R3C 0J7

Email: [access@gov.mb.ca](mailto:access@gov.mb.ca)

Website: [AccessibilityMB.ca](http://AccessibilityMB.ca)

Phone: 204-945-7613

Toll-Free: 1-800-282-8069, Ext. 7613

The design of accessible outdoor public spaces requires the participation of all people; designers, builders, persons with disabilities, and other stakeholders, including property owners and governments. Their diverse perspectives will ensure a collaborative process aimed at the greater good.

In order to ensure that all comments receive proper consideration, they must be received no later than **February 14, 2020**, prior to the preparation of the Committee's recommendations. The final report, including recommendations for a proposed standard for the Design of Public Spaces, will be submitted to the Minister of Families by March 31, 2020. The report will be publicly available and posted on the Disabilities Issues Office website, [AccessibilityMB.ca](http://AccessibilityMB.ca).

# TABLE OF CONTENTS

## SECTION 1

1.1.	Intent	7
1.2.	General Application	8
1.3.	Compliance	8
1.4.	Schedule	8
1.5.	Transition	9
1.6.	Establishment of Policies	9
1.7.	Dimensions and Tolerances	9
1.8.	Document Format	9
1.9.	Definitions	10

## SECTION 2 DESIGN REQUIREMENTS

2.1.	Accessible Path of Travel	14
2.2.	Ramps	21
2.3.	Stairs	22
2.4.	Mechanical lifts	23
2.5.	Pedestrian Crossings	24
2.6.	Bike Lanes and Paths	26
2.7.	Exterior Parking and Loading zones	34
2.8.	Signage	38
2.9.	Controls	42
2.10.	Hearing Assistance Systems	43
2.11.	Lighting	44
2.12.	Counters, Tables and Service Desks	45
2.13.	Benches and Seating	47
2.14.	Washrooms	47
2.15.	Play areas	49
2.16.	Sports facilities	54
2.17.	Docks / Boat Launches	56
2.18.	Beach Routes and Recreational Trails	58

## SECTION 3 OPERATIONS

3.1.	Maintenance	62
3.2.	Snow clearing	62

## APPENDIX 1 REFERENCES

## **1.1. INTENT**

- 1.1.1 This standard specifies Technical requirements to make the exterior built environment accessible and safely usable by persons with physical, sensory and cognitive disabilities. It describes minimum technical requirements that shall guide the design and construction of exterior environments, and modifications to existing exterior built environments.
- 1.1.2 The Design of Public Spaces Accessibility Standard is intended to identify applicable Codes and standards related to exterior public spaces and fill gaps where no Code or standard is in place. It is written to complement the requirements of existing Codes, standards, and bylaws. Where there is compelling evidence, this Standard identifies places where revisions or updates are recommended to those documents.
- 1.1.2.1 All community spaces, such as plazas, public monuments, cemeteries and community gardens, are to be included in this Standard. Site furniture such as lighting standards, mailboxes, trash receptacles, planters, tables, kiosks, and telephone enclosures should be located off clear areas and the path of travel and be accessible to people using wheelchairs. They should not interfere with comfortable movement or the full use of the community space.
- 1.1.3 This standard is to be read in conjunction with the following existing Codes and Standards:
- (a) Manitoba Building Code M.R. 31/2011
  - (b) Manitoba Fire Code M.R. 155/2011
  - (c) CSA B651-18 Accessible Design for the Built Environment
  - (d) CSA Z614-14 (R2019) Children's Playspaces and Equipment
  - (e) TAC Geometric Design Guide for Canadian Roads, Chapter 6 and Chapter 8.
- 1.1.4 Figures are included for explanatory or illustrative purposes only. If there are any differences between the text and the figure (where provided) the text shall take precedence. (CSA)

**1.2. GENERAL APPLICATION**

1.2.1 Requirements of this Standard apply to newly constructed and *redeveloped* exterior public spaces on or after the dates set out in Paragraph 1.4 Schedule. Emergency repairs to public spaces and outdoor facilities are not required to meet the Standard, however, temporary facilities such as construction access routes and seasonal patios are required to comply.

1.2.2 The accessibility standard for the Design of Public Spaces applies to any organization (public, private, non-profit) that constructs or redevelops any public space to which this standard applies. Organizations subject to this standard are:

- (a) The Government of Manitoba;
- (b) Public Sector organizations;
- (c) All private and non-profit organizations.

**1.3. COMPLIANCE**

1.3.1 Compliance with this Standard will be achieved by:

- (a) implementing the applicable solutions described in the Section 2 Design Requirements; or
- (b) using alternative solutions that will meet the Intent and achieve at least the minimum functional requirements as described in the related subsection.

**1.4. SCHEDULE**

Once the standard comes into force, obligations will be phased in over three years affecting new projects of the Manitoba Government, Public Sector, and all other organizations as follows.

Type	Timeframe
<b>Manitoba Government</b>	After one year
<b>Public Sector Organizations except small municipalities</b>	After two years
<b>All other organizations</b>	After three years



Question: Do you agree with the proposed schedule, noting that the standard only applies to contracts and projects after the standard comes into force?

## **1.5. TRANSITION**

1.5.1 The Standard applies to projects that will result in public spaces being built on or after the Standard comes into force. This transition clause only makes an exception for contracts signed on or before the Standard comes into force.

## **1.6. ESTABLISHMENT OF POLICIES**

1.6.1 Every organization subject to the standard shall develop policies, practices and procedures to meet the requirements set out in this standard.

## **1.7. DIMENSIONS AND TOLERANCES**

1.7.1 This Standard contains minimum requirements based on adult dimensions. The dimensions are provided in metric units. Linear dimensions are displayed in millimeters, unless otherwise noted. Where units have been converted from Imperial (feet, pounds, etc.) they are rounded to the closest metric equivalent, typically to the nearest 5 mm, except where tolerances are critical and greater precision is required, such as for grate openings or threshold lips. All dimensions in figures are measured to the centreline, unless otherwise specified.

## **1.8. DOCUMENT FORMAT**

1.8.1 This document has been formatted to facilitate public review. Each of the sections includes its own intent statement, applications, exclusions, and design requirements. Within the design requirements, Design Notes have been included that are not regulatory, but help provide context and guidance on the application of the standard and other considerations. To differentiate them from regulatory standards, Design Notes are set in bordered text boxes.

## **1.9. DEFINITIONS**

- 1.9.1 Boat slip – is the portion of a pier, main pier, finger pier, or float where a boat is berthed or moored, or used for embarking or disembarking.
- 1.9.2 CNIB – Canadian National Institute for the Blind
- 1.9.3 Colour Rendering Index – a measure of the ability for a light source to reveal colours faithfully, in comparison with a reference source, often sunlight.
- 1.9.4 Cross slope – is the slope measured perpendicular to the typical path of travel.
- 1.9.5 CSA - Canadian Standards Association
- 1.9.6 Curb ramp - is a graded transition between the sidewalk and the street, linking the sidewalk seamlessly with the pedestrian crossing that it serves.
- 1.9.7 Facility access point - location at which one gains entrance to the primary area of activity and/or the general assembly or foyer space within a built structure.
- 1.9.8 Gangway – is a variable-sloped pedestrian walkway linking a fixed structure or land with a floating structure.
- 1.9.9 Heavily Patterned – a pattern where there are multiple changes in contrast within a 300mmx300mm square that can have a visual affect creating dizziness or imbalance.
- 1.9.10 Hearing Assistance System – devices that can be integrated into an environment to amplify select signals that are receivable by people using hearing aids.
- 1.9.11 Illumination – light intensity, as measured in lux.
- 1.9.12 Level – less than 2% slope in any direction.
- 1.9.13 Light distribution – the pattern of light on a surface. Manufacturers offer different distribution patterns for different applications – for example sidewalks might use the long narrow Type I distribution, while parking areas benefit from the square Type VS.
- 1.9.14 Maintenance - are activities that are intended to keep existing public spaces in good working order. Maintenance can also

include the restoration of deteriorated space or element back to its original condition. Maintenance work could include painting or minor repairs.

- 1.9.15 MBC - Manitoba Building Code
- 1.9.16 NBC – National Building Code
- 1.9.17 Pedestrian Through Zone - Is the area intended to be clear and navigable for pedestrian travel, free of permanent and temporary obstructions. It is considered the area of clear sidewalks and does not include the frontage or furnishing zones which may be part of the overall sidewalk width.
- 1.9.18 Prevailing construction practices - are those methods typically used by local contractors and designers when faced with the same or similar design conditions.
- 1.9.19 Push ramp – is an auxiliary sloped surface adjacent to a set of stairs in an exterior path of travel that has the same rise and run as the adjacent stairs, has a narrow width, and is solely dedicated to the movement of unoccupied wheeled devices as an alternative to transitioning the actual stairs with the device.
- 1.9.20 Redevelopment - means significant planned changes to a public space, e.g., resurfacing or expanding a parking lot. It does not include maintenance activities, environmental mitigation or environmental restoration.
- 1.9.21 Running slope – is the slope measured parallel to the typical path of travel also known as longitudinal slope.
- 1.9.22 Sport Facility - that portion of a space where the play or practice of a sport occurs as per the governing body responsible for that sport, and/or the design criteria placed on the safe and active use of a space for the designated sport.
- 1.9.23 TAC – Transportation Association of Canada
- 1.9.24 Tactile Walking Surface Indicators (TWSI) – as specified by CNIB provide critical information indicating the presence of a hazard to people who are blind and partially-sighted. The intent of their application is to provide attention to a street crossing, drop-off, or potential hazard ahead/adjacent to. The first priority in their

installation should be to consider protecting the individual from entering a hazard from all angles of approach.

- (a) A tactile walking surface indicator (TWSI) surface shall be composed of circular, flat-topped, truncated domes or cones:
- (i) with a height of between 4mm and 5mm;
  - (ii) with the top diameter between 12mm and 25mm and the base diameter 10mm ± (1mm) greater than the top diameter;
  - (iii) arranged in a square grid parallel to the main direction of travel; and
  - (iv) with a centre-to-centre distance of adjacent domes conforming with Table 1.

Top diameter of flat-topped domes or cones (mm)	Spacing between the centres of adjacent domes or cones (mm)
12	42 to 61
15	45 to 63
18	48 to 65
20	50 to 68
25	55 to 70

Table 1 – Centre to Centre Distances

- 1.9.25 Threatened, Endangered, at Risk and Extirpated Species and Ecosystems - are identified in the Threatened, Endangered and Extirpated Species Regulation or the Threatened and Endangered Ecosystems Regulation. Both regulations are found under The Endangered Species and Ecosystems Act in Manitoba.
- 1.9.26 Transition Plates – are sloping pedestrian walking surfaces located at the end of a *gangway*.

1.9.27 Unexpected drop off edge - a drop of more than 200mm not generally anticipated within the context of the surrounding environment.

**Question: Are there any additional definitions, or clarifications to the definitions, that are required?**

## SECTION 2 DESIGN REQUIREMENTS

### 2.1. ACCESSIBLE PATH OF TRAVEL

#### 2.1.1 Intent

2.1.1.1 The accessible path of travel is critical to all aspects of the design of public spaces. Ensuring access to both the functional and experiential components of the public realm is a priority that must be addressed in a manner that provides equal access while maintaining the contextual integrity of the spaces being considered.

#### 2.1.2 Related Sections

(a) All sections of this Design of Public Spaces Standard shall consider this section.

#### 2.1.3 Application:

2.1.3.1 The requirements for an accessible path of travel apply to the development of all exterior public spaces.

2.1.3.2 An accessible path of travel may include level walking surfaces, sloped surfaces, and ramps.

2.1.3.3 It is imperative that any additional elements added to the public realm, of a temporary or permanent nature, do not obstruct the accessible path of travel. Such elements may include, but are not limited to:

(a) seasonal commercial patios

(b) construction scaffolding/ barricades

(c) signage

(d) trees

(e) site furniture (e.g. planters, seating, bike racks)

#### 2.1.4 Exceptions

2.1.4.1 Where the site conditions indicate that the design and construction of an accessible path of travel is not practicable due to natural terrain.

2.1.4.2 Where the site conditions will require construction processes that cannot be accomplished with the *prevailing construction practices* and require the use of construction equipment or methods other than those typically used in a particular type of setting.

- 2.1.4.3 Where the design and/or construction would fundamentally alter the function or purpose of the surrounding setting.
- 2.1.4.4 Where an accessible path of travel is subject to exception (above), every effort shall be made to incorporate,
  - (a) appropriate signage as per 2.8.5.11.
  - (b) rest areas adjacent to the trail, pathway or walkway that are:
    - (i) level rest areas that are a maximum of 30 metres apart, and
    - (ii) have accessible ground surfaces
- 2.1.5 Design
  - 2.1.5.1 An accessible path of travel must have a minimum clear width 1200mm.
  - 2.1.5.2 Where an accessible path of travel is less than 1500mm wide, an unobstructed passing space of not less than 1830mm wide by 1830mm long, located not more than 30 meters apart must be provided.
  - 2.1.5.3 All viewing areas, overlooks, or “points of interest’ adjacent to an accessible path of travel shall incorporate, an 1830mm wide by 1830mm long level area to allow others to freely move past.
  - 2.1.5.4 An accessible path of travel must have a minimum 2500 mm headroom clearance height.
  - 2.1.5.5 Accessible paths of travel shall have a firm stable surface that will reasonably withstand exposure to typical weather conditions for the particular site. The surface of the accessible path of travel may include materials such as asphalt, concrete, pavers, lumber, or highly compacted fine granular material. Irregular surfaces along an accessible path of travel must be avoided.
  - 2.1.5.6 Openings within the surface of an accessible path of travel shall
    - (a) have no openings that will permit the passage of a sphere more than 13 mm in diameter, and
    - (b) have any elongated openings oriented approximately perpendicular to the direction of travel.
  - 2.1.5.7 The maximum cross slope of an accessible path of travel shall be 1 in 50.

- 2.1.5.8 An accessible path of travel having a running slope of 1 in 20, or less, is considered an accessible path of travel.
- 2.1.5.9 Any changes in elevation less than 200mm along an accessible path of travel are not considered a ramp or a step, if:
  - (a) any abrupt changes in elevation not more than 13mm shall be bevelled at a maximum running slope of 1 in 2,
  - (b) any abrupt changes in elevation more than 13mm and less than 200mm have a running slope no less than 1 in 12 (for example: at pedestrian crossings where 2.1.5.12 must apply)
- 2.1.5.10 An accessible path of travel with changes in elevation more than 200mm must be treated as a ramp as per Section 2.2 Ramps.
- 2.1.5.11 Any stairs within or adjacent to an exterior accessible path of travel shall comply with Section 2.3 Stairs.
- 2.1.5.12 A *tactile walking surface indicator (TWSI)* shall be used within the accessible path of travel where a change in elevation is such that a stair and/or ramp is used, and must be the full width of the stairs or ramp.
- 2.1.5.13 A *tactile walking surface indicator (TWSI)* surface shall be located at the top of any stairs within, or adjacent to an accessible path of travel and shall be a minimum of 900 mm deep, starting one tread depth back from the edge of the stair.
- 2.1.5.14 Except at stairs, performance platforms, loading docks, and sidewalks adjacent to roadways and parking lots, where an unexpected drop off edge is created that exceeds 75mm above an adjacent surface and the drop-off is within 600mm of the accessible path of travel, then edge protection shall be provided by a continuous curb at least 75mm high; or; a guard in compliance with *MBC*.
- 2.1.5.15 Where edge protection is provided it must allow for proper drainage in order to prevent the accumulation of ice and water.
- 2.1.5.16 The walking surfaces of ramps, landings and treads within an accessible path of travel shall have a finish that is slip-resistant.
- 2.1.5.17 All accessible paths of travel shall produce minimal glare and not be heavily patterned.
- 2.1.5.18 An accessible path of travel that is shared with other users, such as cyclists, in-line skaters, etc. shall:



- (a) designate the separate usage by signage that complies with Section 2.8 Signage

**Design Note:**

The following should be considered when designing accessible routes of travel:

- Informational signage be provided to assist people moving through the area to clearly understand the terrain and amenities complying with Section 2.8.
- Wayfinding strategies (directional signage) be provided to assist people moving through the area to clearly understand how to manoeuvre through the space safely, effectively and equitably. Signage shall comply with Section 2.8.

**Question: Are the pedestrian crossings requirements presented sufficient to meet the needs of people disabled by barriers? Are there additional requirements that should be considered to improve the standard?**

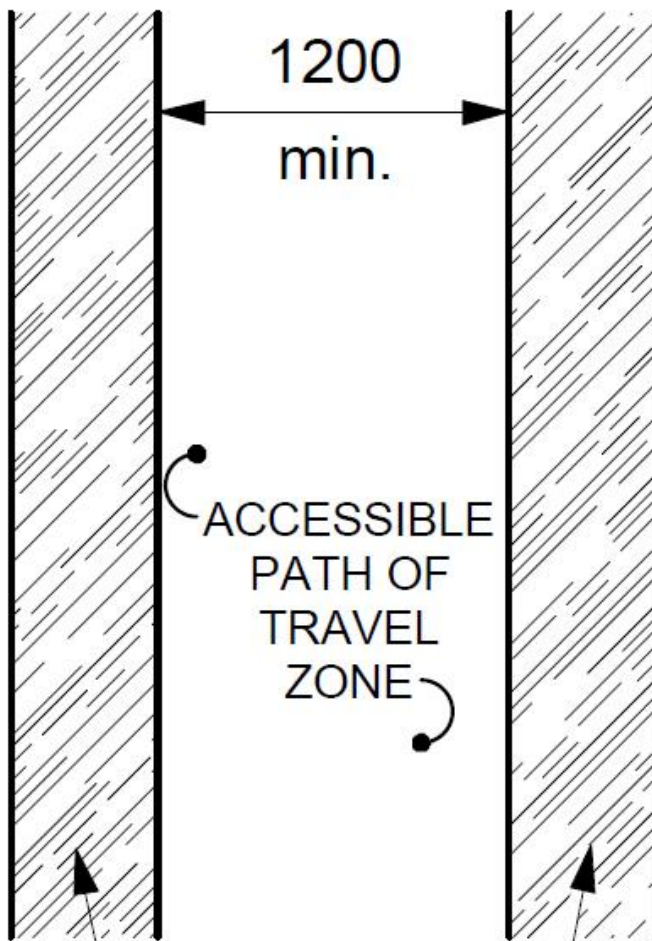

Planters, trees, seating, signage, bike rack, etc. to be located outside of Accessible Path of Travel zone

Figure 2.1.5.1 from CSA

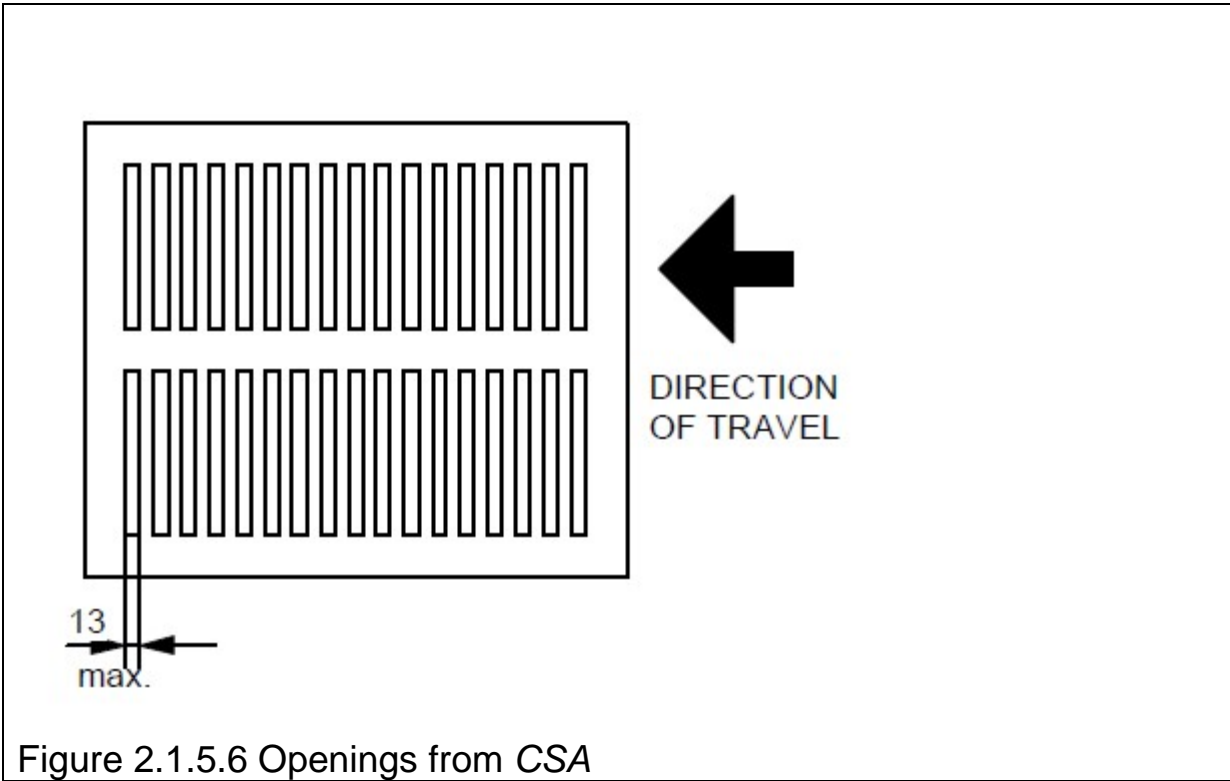

Figure 2.1.5.6 Openings from CSA

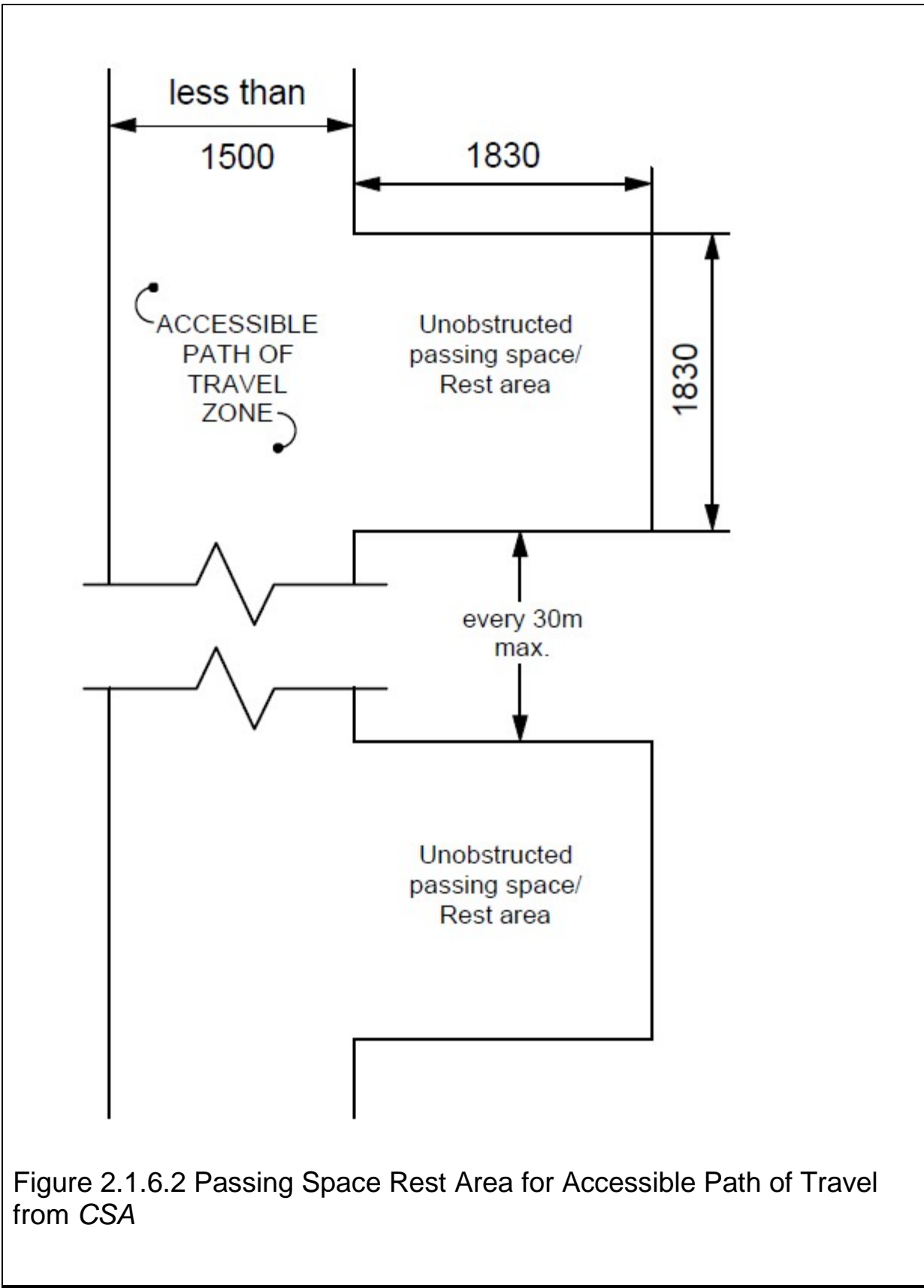

Figure 2.1.6.2 Passing Space Rest Area for Accessible Path of Travel from CSA

## **2.2. RAMPS**

### 2.2.1 Intent

2.2.1.1 Ramps are intended to provide access to both the functional and experiential components of the public realm where a grade change is required. A ramp must be addressed in a manner that provides equal access while maintaining the contextual integrity of the spaces being considered.

### 2.2.2 Related Sections

- (a) 2.1. Accessible path of travel
- (b) 2.3. Stairs
- (c) 2.4. Mechanical lifts
- (d) 2.5. Pedestrian Crossings
- (e) 2.7. Exterior parking and loading zones
- (f) 2.8. Signage
- (g) 2.15. Play areas
- (h) 2.16. Sports facilities
- (i) 2.17. Docks / Boat Launches

### 2.2.3 Application

2.2.3.1 Access to all ramps must adhere to accessible paths of travel standard.

### 2.2.4 Exceptions

2.2.4.1 Where the path of travel limits the ability for accessibility in respect to the natural landscape.

### 2.2.5 Design

2.2.6 A ramp shall not have a running slope greater than 1 in 12.

Design Note: Minimize slope on ramps where feasible to allow for easier access. The 1 in 12 slope should be used only where required for constricted spaces.
--

2.2.6.1 Any accessible path of travel having a running slope steeper than 1 in 20 shall be designed as a ramp.

2.2.6.2 A ramp within an accessible path of travel shall not be curved.

2.2.6.3 A ramp located within an accessible path of travel shall have a clear width not less than 900mm between handrails or between the inside of the guard(s).

2.2.6.4 All ramps within an accessible path of travel shall comply with *MBC*.

**Design Note:**

Ramps that surmount a major change in level (vertical rise) have to be very long and require multiple ramp and landing combinations. In such circumstances, other design solutions should be considered.

2.2.6.5 All ramps and landings shall have a colour and texture contrast to demarcate the leading edge of the landing at both the beginning and end of a ramp.

2.2.6.6 The requirement for handrails need not apply to a ramp serving as an aisle for fixed seating.

## **2.3. STAIRS**

2.3.1 Intent

2.3.1.1 Stairs are intended to provide access to both the functional and experiential components of the public realm where a grade change is required. Stairs must be addressed in combination with accessibility for those using wheel-based mobility supports, while maintaining the contextual integrity of the spaces being considered.

2.3.2 Related Sections

- (a) 2.1. Accessible path of travel
- (b) 2.2. Ramps
- (c) 2.4. Mechanical lifts
- (d) 2.5. Pedestrian Crossings
- (e) 2.7. Exterior parking and loading zones
- (f) 2.8. Signage
- (g) 2.15. Play areas
- (h) 2.16. Sports facilities
- (i) 2.17. Docks / Boat Launches

- 2.3.3 Application
  - 2.3.3.1 Access to all stairs must adhere to accessible paths of travel standards.
- 2.3.4 Exceptions
  - 2.3.4.1 Where the path of travel limits the ability for accessibility in respect to the natural landscape.
- 2.3.5 Design
  - 2.3.5.1 Any stairs within or adjacent to an accessible path of travel shall comply with *MBC*.
  - 2.3.5.2 Where the natural terrain limits the ability for the rise / tread ratio to comply with 2.3.5.1:
    - (a) a consistent tread length and rise height shall be applied where the rise height is no less than 75mm, and no greater than 180mm and a tread length is no less than 300mm, and no greater than 600mm.
    - (b) requirements for handrails as per *MBC*, must still apply.
  - 2.3.5.3 Stairs within an accessible path of travel shall not have open risers.
  - 2.3.5.4 All landings and stair treads shall have a colour and texture contrast to demarcate the leading edge of the tread or the nosing.
  - 2.3.5.5 *Push ramps* may be incorporated into a stair and shall be a minimum of 100mm to a maximum of 250mm in width, or 300mm when adjacent to a handrail.

## **2.4. MECHANICAL LIFTS**

- 2.4.1 Intent
  - 2.4.1.1 Mechanical lifts are intended to provide access to both the functional and experiential components of the public realm where a substantial grade change is required. A mechanical lift must be addressed in a manner that provides equal access while maintaining the contextual integrity of the spaces being considered and safeguarding against risk of accidents associated with the operation of such equipment.
- 2.4.2 Related Sections
  - (a) 2.1 Accessible Path of Travel

- (b) 2.2 Ramps
- (c) 2.8 Signage
- (d) 2.9 Controls
- (e) 2.11 Lighting

### 2.4.3 Application

2.4.3.1 A platform lift may be used as a part of an accessible exterior path of travel in lieu of an elevator or ramp where it is technically not feasible to accommodate the requirements of 2.2 for a ramp.

### 2.4.4 Design

2.4.4.1 The staging area outside of the mechanical lift must allow for sufficient space for individuals to be waiting for use without impeding the accessible path of travel.

2.4.4.2 A mechanical lift provided as a passenger elevating device as a part of the exterior accessible path of travel shall conform to the latest edition of CAN/CSA-B355. "Lifts for Persons with Physical Disabilities" or Appendix E of ASME A17.1/CSA-B44 (for an accessible elevator),

## 2.5. PEDESTRIAN CROSSINGS

### 2.5.1 Intent

2.5.1.1 Design of the interface between motor vehicles and pedestrians of all abilities requires thoughtful consideration of safety, circulation patterns, movement habits and equal access. Pedestrian Crossings are intended to provide safe harbour, ease of movement and limit exposure to conflicting traffic where the pedestrian realm meets a vehicular right of way. Pedestrian crossings and intersections with pedestrian access must be addressed in a manner that provides equal access while ensuring pedestrian safety.

### 2.5.2 Related Sections

- (a) 2.1 Accessible path of travel
- (b) 2.2 Ramps
- (c) 2.4 Mechanical lifts
- (d) 2.6 Bike Lanes and Paths
- (e) 2.7 Exterior Parking and Loading



- (f) 2.8 Signage
- (g) 2.9 Controls
- (h) 2.11 Lighting

### 2.5.3 Application

2.5.3.1 The requirements for pedestrian crossings apply to all roadways accessible to the public where pedestrian facilities are provided including pedestrian overpasses and underpasses and general intersection design.

2.5.3.2 Access to pedestrian crossings must adhere to the accessible paths of travel standard.

### 2.5.4 Exceptions

2.5.4.1 Except where the natural form of the land does not allow for road grades that conform with typical grade requirements and subsequently it is not feasible to meet all pedestrian crossing grade or other requirements.

### 2.5.5 Design

2.5.5.1 Pedestrian crossings shall be in conformance with the TAC Geometric Design Guide for Canadian Roads Chapter 6 – Pedestrian Integrated Design.

2.5.5.2 In addition to conforming with TAC Geometric Design Guide for Canadian Roads Chapter 6 – Pedestrian Integrated Design, the following supplemental requirements apply:

- (a) Where not a raised crossing, provide a dedicated *curb ramp* for each direction of travel.

**Design Note:**

The spacing between ramps on a corner requires specific grading design where they are close together as the flares on the ramps overlap. The curb height may need to be lowered to reduce damage by vehicles and snow clearing.

- (b) Pedestrian crossings shall be perpendicular to the vehicle route being crossed.
- (c) Pedestrian crossings shall clearly indicate where crossing should occur.

- (d) Pedestrian crossings shall be free of obstructions and allow pedestrians to see and be seen by traffic while waiting to cross and while crossing.
- (e) Pedestrian crossings shall have corner radii designed to ensure vehicles do not drive over the pedestrian area.

**Design Note:**

The following should be considered when designing pedestrian crossings:

- i. A raised pedestrian crossing should be considered first where it does not impede emergency or transit operations.
- ii. Crossing distances at intersections should be minimized (consider curb extensions, smaller corner radii, median refuge islands, fewer travel lanes, and narrower travel lanes).
- iii. Be made available at appropriate intervals which match the pedestrian demand to cross the roadway.
- iv. Where signage is required based on *TAC* compliance, it should meet the intent of (Signage) Section wherever possible and when it is not in contradiction of *TAC*.

**Question: Are the pedestrian crossings requirements presented sufficient to meet the needs of people disabled by barriers? Are there additional requirements that should be considered to improve the standard?**

## **2.6. BIKE LANES AND PATHS**

### 2.6.1 Intent

2.6.1.1 These standards provide guidance for integrating hand-cycle, racing chair and other wheeled mobility devices into the design considerations for all exterior paths of travel intended for use by bicycles.

### 2.6.2 Related Sections

- (a) 2.1 Exterior accessible path of travel
- (b) 2.2 Ramps
- (c) 2.8 Signage

### 2.6.3 Application

2.6.3.1 These standards apply to multi-use and active transportation paths, and bicycle paths considered within roadway geometric design, including roadways and intersections.

## 2.6.4 Design

2.6.4.1 An exterior accessible path of travel that is shared with other users, such as cyclists, in-line skaters, etc., shall conform with Transportation Association of Canada (TAC) Geometric Design Guide for Canadian Roads Chapter 5 – Bicycle Integrated Design, with the additional consideration that these standards do not reflect the operating space / dimensions specific to hand-cycles and racing chairs, and the associated increased minimum turning radii and shall be increased where feasible.

### Design Note:

The following revisions are recommended:

- (a) transitions between bike lanes and bike paths require a minimum clear opening of 4m (cross-ref minimum ramp width in Figure 5.6.5 TAC p 50), and;
- (b) minimum tapers at bend-in and bend-out configurations for multi-use paths should be increased from 1:3 to 1:5
- (c) minimum widths of openings of On-Ramps and Off-Ramps should be 4m (cross-ref Figure 5.6.17 TAC p 63)
- (d) minimum radii and depths of turns at bikeway crossings at high-speed on/off ramps should be at least 6m (cross-ref Figure 5.6.18 TAC p 65)
- (e) minimum openings of bike ramps (TAC 5.7.3) should be at least 4.5m (cross-ref Figure 5.7.1 TAC p 70)
- (f) minimum openings between contiguous delineators for transitions between protected bike lanes should be at least 4.5 m (cross-ref Figure 5.7.1 and 5.7.4 and not specified TAC p 70 – 77)
- (g) signage complying with Section 2.8 be provided indicating the level of accessibility of the path or lane and alternate accessible routes if applicable.

Figures from TAC:

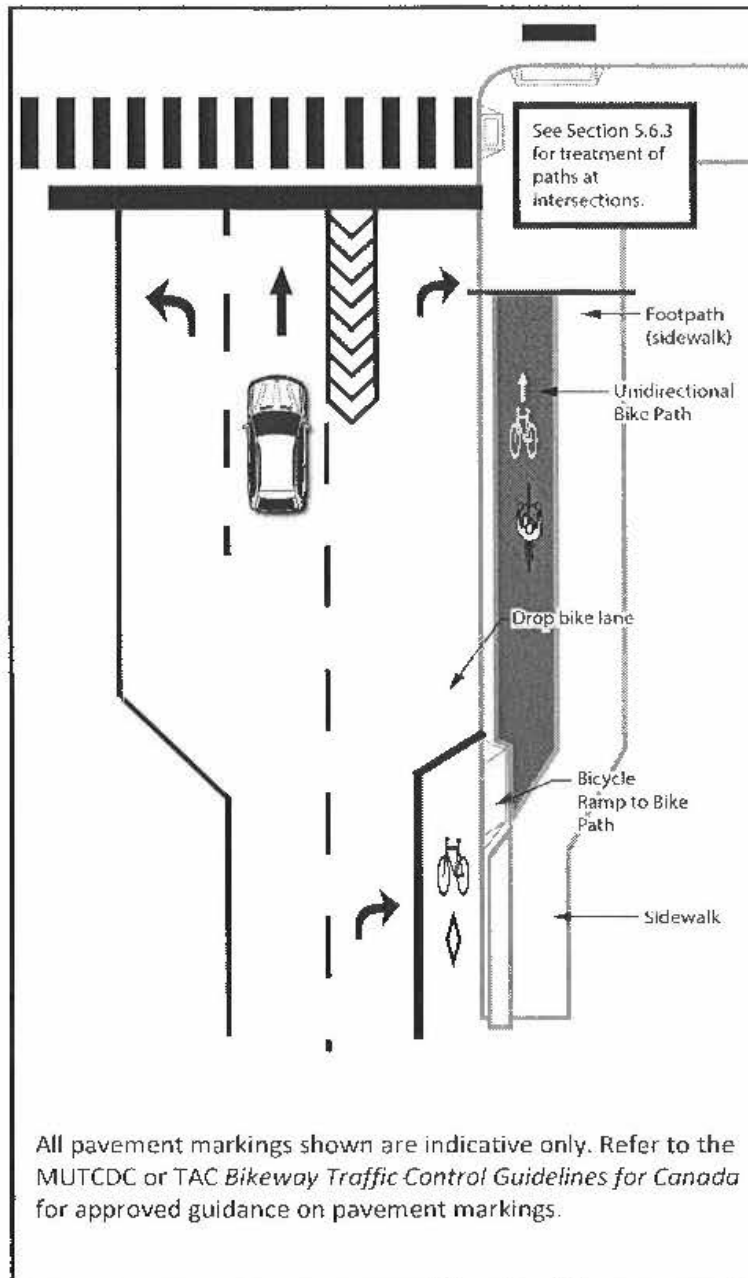

**Figure 5.6.5: Bike Ramp to Bike Path**

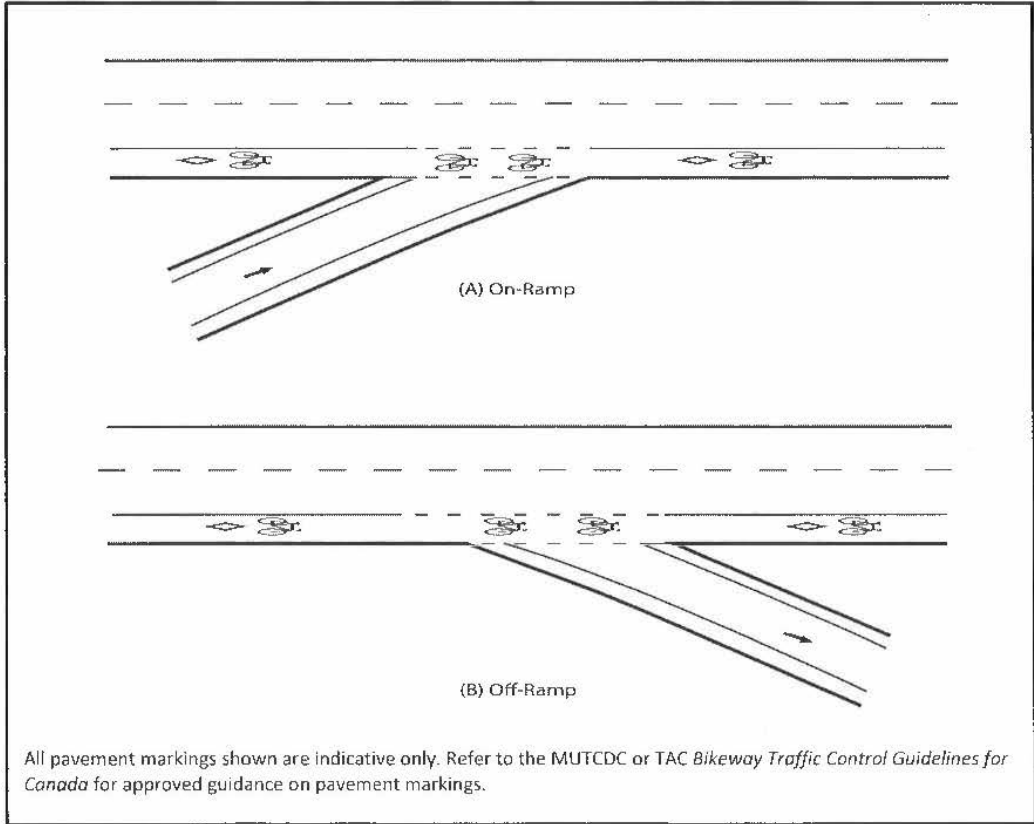

**Figure 5.6.17: Bikeway Crossing Low-Speed On/Off Ramps**

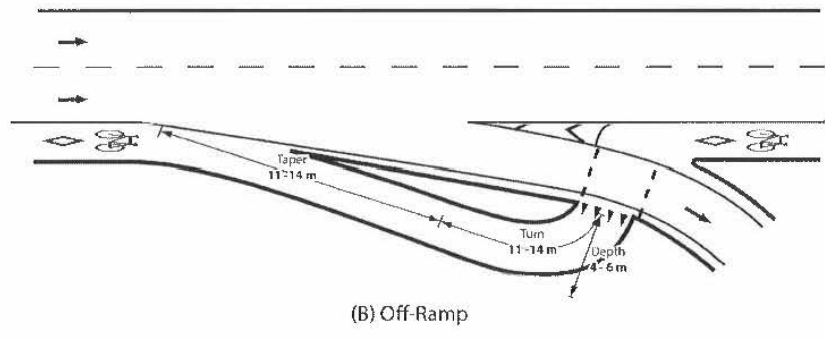
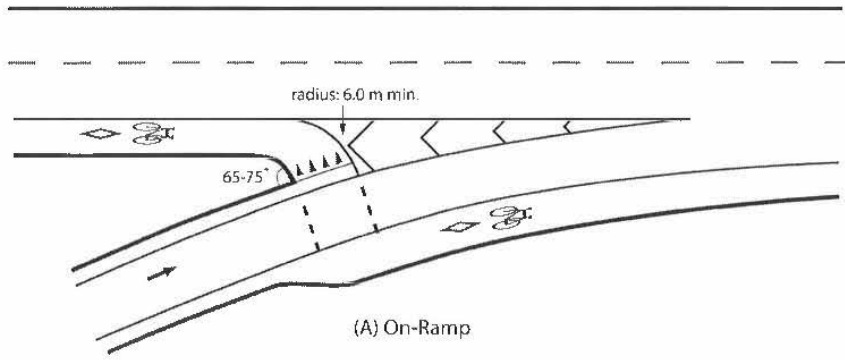

All pavement markings shown are indicative only. Refer to the MUTCDC or TAC *Bikeway Traffic Control Guidelines for Canada* for approved guidance on pavement markings.

**Figure 5.6.18: Bikeway Crossing High-Speed On/Off Ramps**

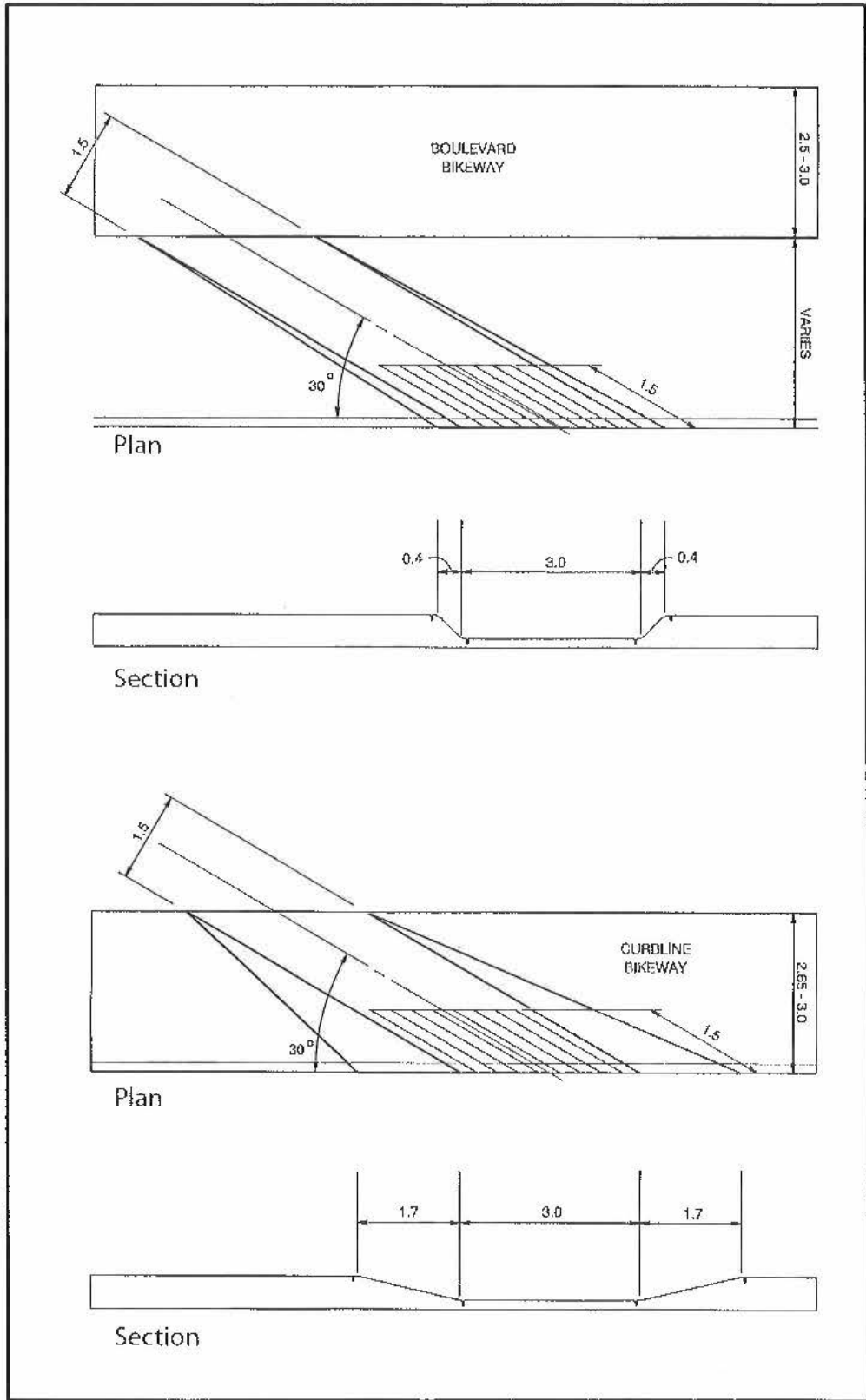
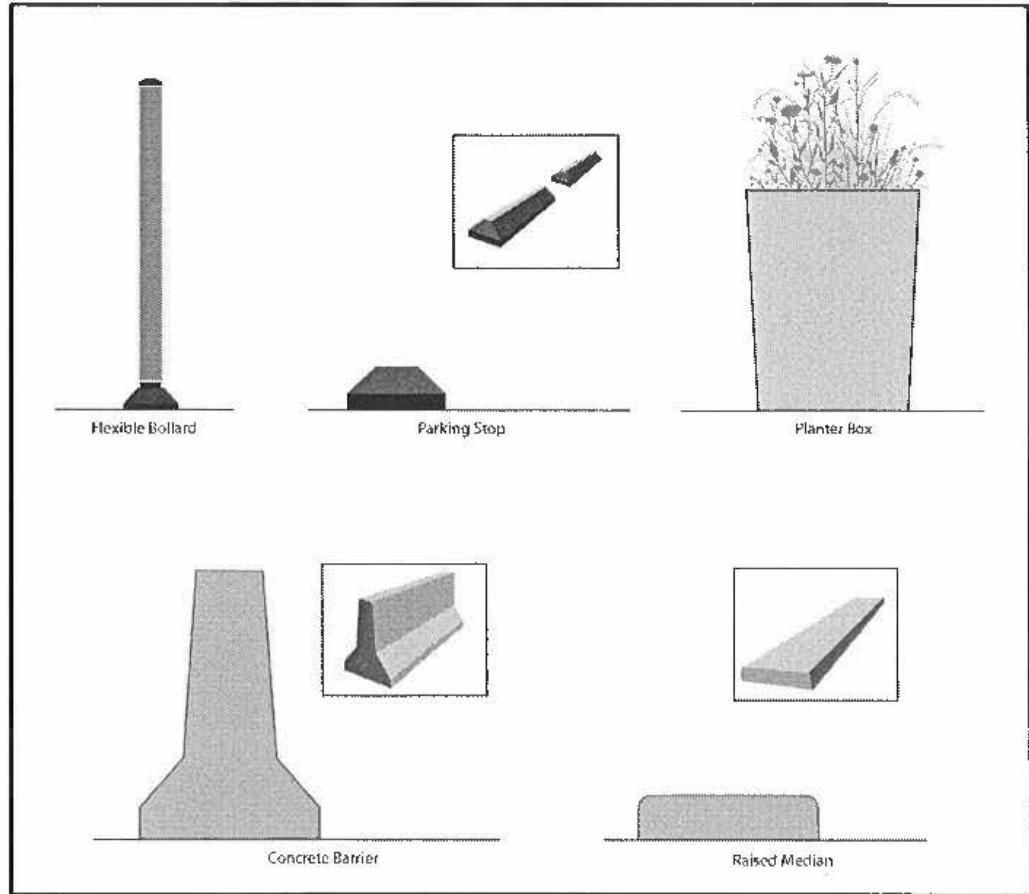
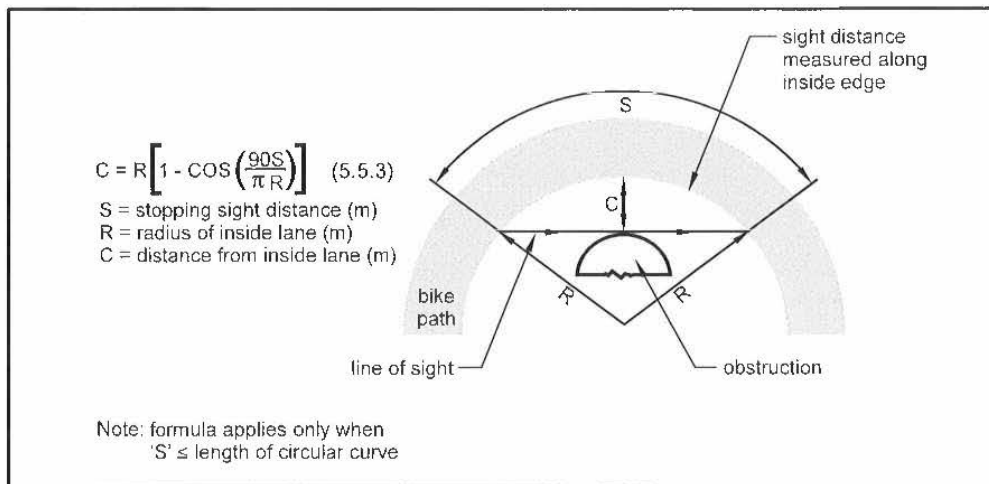

Figure 5.7.1: Bike Ramp



**Figure 5.7.4: Protected Bike Lane Delineators**

Figure 5.5.1 illustrates the method of measurement and gives a mathematical expression for the calculation of lateral clearance. Table 5.5.3 gives the lateral clearance for a range of radii from 10 m to 80 m and stopping sight distances from 10 m to 100 m. The lateral clearance values shown occur at the midpoint of the curve.



**Figure 5.5.1: Lateral Clearance for Stopping Sight Distance**



## Tables from TAC

Table 5.5.3:Lateral Clearance for Bicycles on Horizontal Curves

Lateral Clearance on Horizontal Curves (m)										
Radius (m)	Stopping Sight Distance (m)									
	10	20	30	40	50	60	70	80	90	100
10	1.2	4.6	9.3	-	-	-	-	-	-	-
15	0.8	3.2	6.9	11.5	-	-	-	-	-	-
20	0.6	2.4	5.4	9.2	13.7	18.6	-	-	-	-
25	0.5	2.0	4.4	7.6	11.5	15.9	20.8	-	-	-
30	0.4	1.7	3.7	6.4	9.8	13.8	18.2	22.9	27.9	-
35	0.4	1.4	3.2	5.6	8.6	12.1	16.1	20.5	25.2	30.0
40	0.3	1.2	2.8	4.9	7.6	10.7	14.4	18.4	22.8	27.4
45	0.3	1.1	2.5	4.4	6.8	9.6	12.9	16.6	20.7	25.0
50	0.2	1.0	2.2	3.9	6.1	8.7	11.8	15.2	18.9	23.0
55	0.2	0.9	2.0	3.6	5.6	8.0	10.8	13.9	17.4	21.2
60	0.2	0.8	1.9	3.3	5.1	7.3	9.9	12.8	16.1	19.7
65	0.2	0.8	1.7	3.1	4.7	6.8	9.2	11.9	15.0	18.3
70	0.2	0.7	1.6	2.8	4.4	6.3	8.6	11.1	14.0	17.1
75	0.2	0.7	1.5	2.7	4.1	5.9	8.0	10.4	13.1	16.1
80	0.2	0.6	1.4	2.5	3.9	5.6	7.5	9.8	12.3	15.1

Notes: No value is shown where deflection angle exceeds 180° (stopping sight distance > R)

**Question: Are the bike lanes requirements presented sufficient to meet the needs of people disabled by barriers? Are the bike lanes revisions appropriate? Are there additional requirements that should be considered to improve the standard?**

## **2.7. EXTERIOR PARKING AND LOADING ZONES**

### **2.7.1 Intent**

2.7.1.1 Location and design of exterior parking and loading zones for persons with physical disabilities are intended to provide accessible access and egress from vehicles, connecting to an accessible path of travel, during all seasons, from the parking space to the public space, building, or facility.

### **2.7.2 Related Sections**

(a) 2.1 Accessible Path of Travel

(b) 2.8 Signage

### **2.7.3 Application**

2.7.3.1 Exterior parking and loading will apply to both on street and off-street facilities.

2.7.3.2 The requirements for accessible on street parking and loading apply all parking designed along a roadway.

2.7.3.3 The requirements for accessible off street parking and loading apply to all exterior parking areas for public or private parking areas.

### **2.7.4 Exceptions**

2.7.4.1 Where the by-law for the local municipality has requirements that require specific dimensions or quantities that exceed this standard, those standards shall apply.

### **2.7.5 Design**

#### **2.7.5.1 On Street Parking and Loading**

(a) Location of on street parking shall be determined by need for access.

#### **Design Note**

Accessible on street parking stalls should be designed to be within 60m of the access point for a major attraction or have a minimum of 1 stall every 120m along a roadway where street parking is provided.

Where passenger loading is provided, accessible loading zones shall be designed contiguous with standard passenger loading zones.

- (b) Passenger loading zones shall have a *curb ramp* within the loading zone and be adjacent to the accessible path of travel.
- (c) Parallel on street parking and loading stalls shall be a minimum of 2.7m wide and 7.0m long with a *curb ramp* access at the front or back of the space. Where more than one space is provided the ramps can be combined.
- (d) The sidewalk area beside parking and loading spaces is to be clear of impediments such as light poles, fire hydrants, planters, and site furniture.
- (e) All on street parking shall be signed with TAC standard signage RB71 with appropriate arrows.
- (f) All on street loading shall be signed with TAC standard signage RB72 with appropriate arrows.

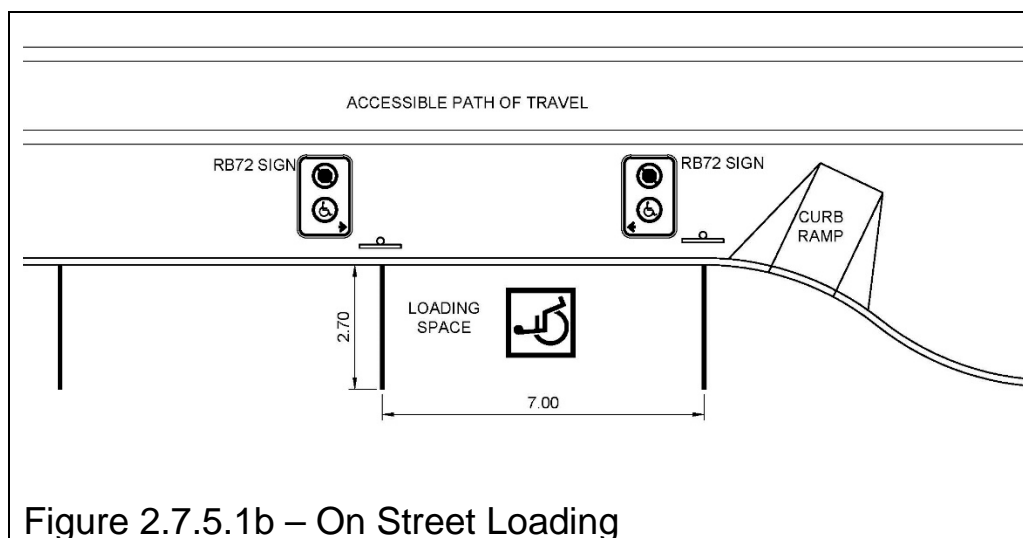
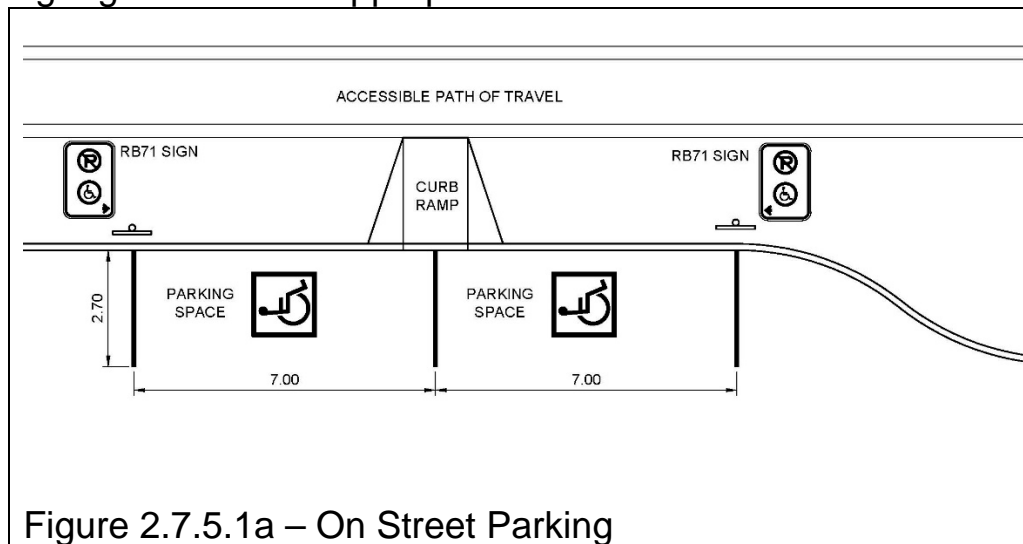

### 2.7.5.2 Off Street Parking and Loading

- (a) Accessible off-street parking stalls shall be designed to be within 60m of the access point to the associated building or facility.
- (b) Parking to be within 15m of the accessible path of travel to the building or facility access point.

**Design Note:**

Consider planning accessible parking directly connected to the accessible path of travel leading the building or facility entrance to allow for protected access.

- (c) Accessible off-street parking stalls shall be a minimum of 3.05m wide unless the stall includes an unobstructed access aisle.
- (d) Parking stalls with an unobstructed access aisle may be 2.45m wide with an aisle 2.45m wide.

**Design Note:**

This type of stall is also known as a Van Accessible stall. The access aisle may be used by two stalls.

- (e) Off street accessible loading is to be a minimum of 3.65m wide and 8m long to allow for multi-passenger vehicle access.
- (f) Loading areas are to be adjacent to the accessible path of travel with a level, unobstructed passenger loading area beside the vehicle.
- (g) All off street parking shall be signed with TAC standard signage RB71 with appropriate arrows.
- (h) All off street loading shall be signed with TAC standard signage RB72 with appropriate arrows.
- (i) All off street parking and loading on a paved surface are to have a painted pavement marking of an international symbol of access painted in a 1.2mx1.2m square with white figure and border on a blue background.

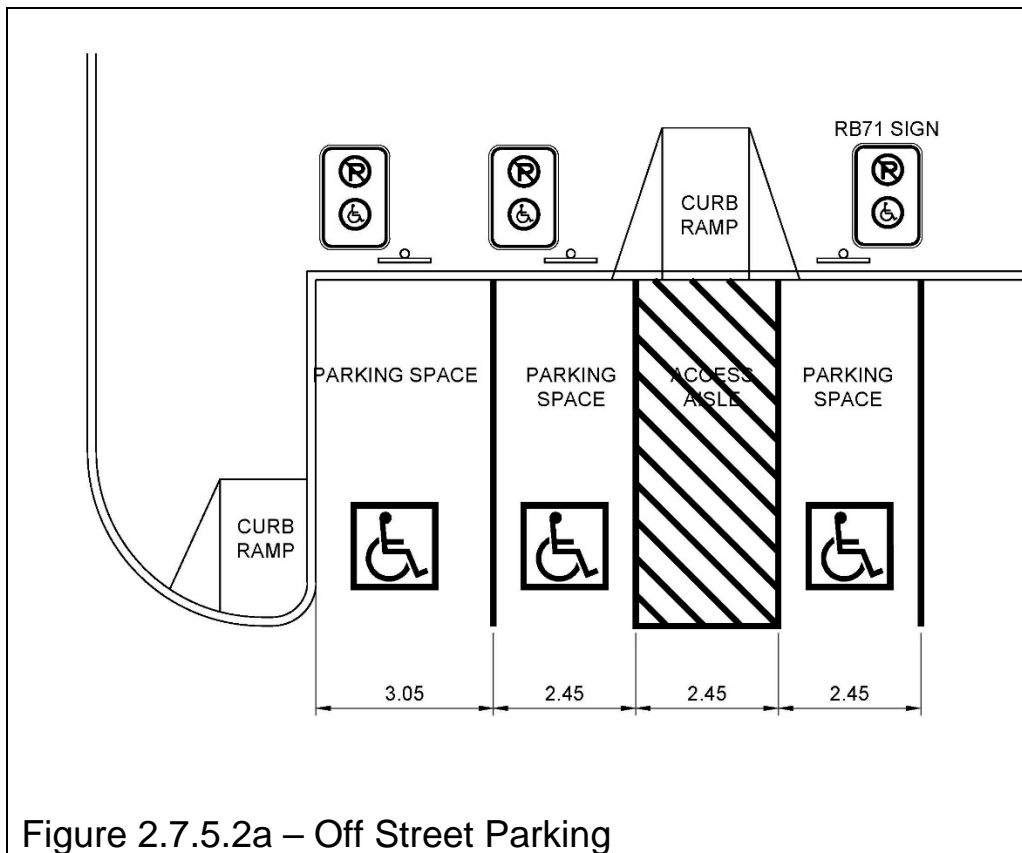

Figure 2.7.5.2a – Off Street Parking

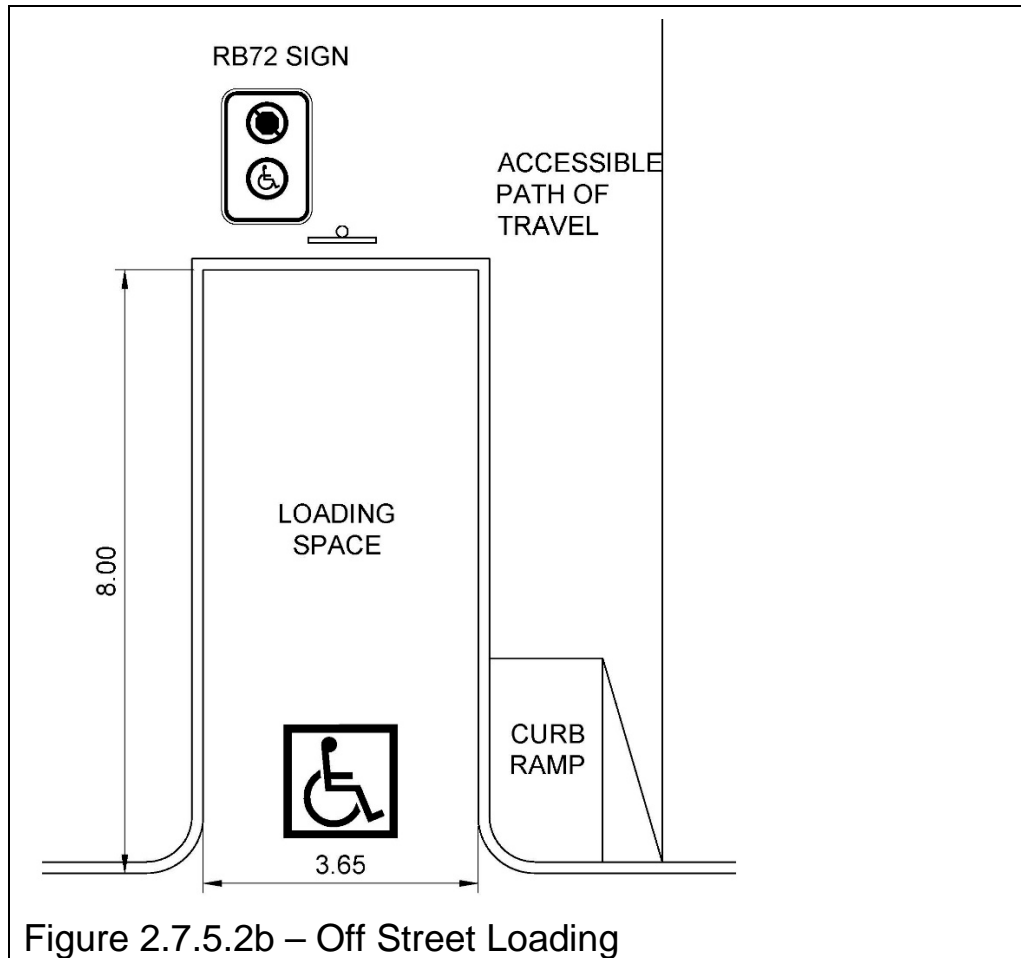

Figure 2.7.5.2b – Off Street Loading

**Question: Are the exterior parking and loading zone requirements presented sufficient to meet the needs of people disabled by barriers? Are there additional requirements that should be considered to improve the standard?**

## 2.8. SIGNAGE

### 2.8.1 Intent

2.8.1.1 To ensure that signs providing information and wayfinding strategies within exterior public spaces are located and designed to be understandable to people with physical and sensory disabilities.

### 2.8.2 Related Sections

- (a) 2.1 Accessible Path of Travel
- (b) 2.2 Ramps

- (c) Mechanical Lifts
- (d) 2.4 Parking
- (e) 2.5 Pedestrian Crossings
- (f) 2.6 Bike Lanes and Paths
- (g) 2.7 Exterior Parking and Loading Zones
- (h) 2.15 Play Areas

### 2.8.3 Application

2.8.3.1 Directional and Information Signs - Signs that provide direction or information about facilities on the site. Interpretive and commemorative signs are not required to comply but are encouraged to meet the intent of the standard.

2.8.3.2 Means of Egress - Signs on the exterior side of exit doors, and signs providing instructions in areas of refuge as defined in the *MBC*.

2.8.3.3 Parking - Accessible Parking spaces shall be identified by signs complying with Section 2.7.

2.8.3.4 Entrances - All accessible entrances shall be identified by the International Symbol of Accessibility.

2.8.3.5 Directional signs complying that indicate an accessible route to the nearest accessible entrance shall be provided at entrances that are not accessible.

2.8.3.6 Exterior Mechanical Lifts -, Where an accessible lift is provided, it shall be clearly identified with the International Symbol of Accessibility.

2.8.3.7 Accessible Public Washrooms - Signs shall include the International Symbol of Accessibility.

2.8.3.8 Beaches, Trails and Wilderness Areas - Provide accessible trailhead signs, located at the entry point to the facility.

### 2.8.4 Exceptions

2.8.4.1 The requirements of this section do not apply to the following:

- (a) Building addresses
- (b) Company names and logos
- (c) Temporary (7 days or less) signs

- 2.8.5 Design
- 2.8.5.1 Location - Where signage, including electronic displays, is provided, it shall be:
- (a) consistently located; and
  - (b) positioned to avoid shadow areas and glare. (CSA)
- 2.8.5.2 Configuration - Where signage, including electronic displays, is provided, it shall
- (a) have a glare-free surface;
  - (b) be of uniform design;
  - (c) when used to give the same type of information within the same facility, be consistently shaped, coloured, and positioned; and
  - (d) be colour-contrasted with its background. (CSA)
- 2.8.5.3 Characters - On signs, letters and numerals shall:
- (a) be sans serif;
  - (b) have Arabic numbers;
  - (c) have a width-to-height ratio between 3:5 and 1:1;
  - (d) have a stroke-width-to-height ratio between 1:5 and 1:10;
  - (e) be colour-contrasted by at least 70% with its background, with light lettering on dark providing the greatest legibility;
  - (f) have the character height relative to the intended viewing distance comply with Table 4; using an upper case "X" for character measurement. (CSA) (sans serif is an AODA requirement)
- 2.8.5.4 Pictograms and Symbols - Pictograms and symbols shall be colour-contrasted by at least 70% with their background. (CSA)
- 2.8.5.5 Tactile Markings - Tactile markings shall supplement the text of:
- (a) regulatory signs, such as prohibition and mandatory signs;
  - (b) warning signs, such as caution and danger signs; and
  - (c) identification signs, such as rooms, titles, names, or numbers. (CSA)
- 2.8.5.6 Tactile Characters - On tactile signs, letters and numerals shall be:
- (a) raised between 0.8mm and 1.5mm above the surface;



- (b) sans serif;
  - (c) 16mm to 50mm in height;
  - (d) accompanied by Grade 1 Braille near the bottom edge of the sign; and
  - (e) colour-contrasted with their background by at least 70%. (CSA)
- 2.8.5.7 Tactile Symbols and Pictograms - On tactile signs, pictograms and symbols shall be:
- (a) raised between 0.8mm and 1.5mm above the surface;
  - (b) at least 150mm in height;
  - (c) accompanied by the equivalent description in Grade 1 Braille, un-contracted and placed directly below the pictogram or symbol; and
  - (d) colour-contrasted with their background by at least 70%.
- 2.8.5.8 Symbols of Accessibility - Where a facility or its elements are required to be identified as accessible, the International Symbol of Access shall be used.
- 2.8.5.9 Symbols of Accessibility - Hearing Disabilities - Signs incorporating the symbol of accessibility for persons with hearing disabilities shall be installed to indicate the location of facilities for persons with hearing disabilities.
- 2.8.5.10 Directional Signs - A directional sign shall:
- (a) provide the necessary information at inaccessible entrances, washrooms, and facilities to reach accessible locations, (MBC)
  - (b) have a clear space free of obstacles or protrusions immediately in front of the sign at least 1500mm long by 900mm wide, (MBC)
  - (c) be mounted with the horizontal centreline 1500mm ( $\pm$  25mm) from the floor, (CSA)
  - (d) have a clear wall area around the sign at least 75mm wide, and (CSA)
  - (e) include appropriate raised text, graphics and braille. (MBC)
- 2.8.5.11 Trailhead Signs - recreational trails must have at each trail head signage that provides the following information:
- (a) The length of the trail.

- (b) The type of surface of which the trail is constructed.
- (c) The average and the minimum trail width.
- (d) The average and maximum running slope and cross slope.
- (e) The location of amenities, where provided.

2.8.6 Where other media, such as park websites or brochures, are used by the obligated organization to provide information about the recreational trail, beyond advertising, notice or promotion, the media must provide the same information as listed in 2.8.5.11.

**Question: Are the signage requirements presented sufficient to meet the needs of people disabled by barriers? Are there additional requirements that should be considered to improve the standard?**

## 2.9. CONTROLS

2.9.1 Intent

2.9.1.1 The controls in public spaces can directly affect an individual's ability to access and fully participate in these environments. It is crucial that the controls installed are operable by all users regardless of age, ability, and/or disability.

2.9.2 Related Sections

- (a) 2.1 Accessible Path of Travel
- (b) 2.4 Mechanical Lifts
- (c) 2.5 Pedestrian Crossings

2.9.3 Application

2.9.3.1 Except as required in section 2.4 Mechanical Lifts, controls for the operation of services or safety devices, including electrical switches and pedestrian activated crossing signals, that are intended to be operated by the general public, and are located in or adjacent to a barrier-free path of travel, shall be accessible to a person in a wheelchair and be operable with one hand.

2.9.4 Design

2.9.4.1 Controls described in this Section shall:

- (a) be mounted 400mm to 1 200mm above the ground,

- (b) be adjacent to and centered on either the length or the width of a clear space of 1 350mm by 800mm,
- (c) be operable with one hand in a closed fist position, without requiring tight grasping, pinching with fingers, or twisting of the wrist, and
- (d) be operable with a force not more than 22 N.

## **2.10. HEARING ASSISTANCE SYSTEMS**

### 2.10.1 Intent

2.10.1.1 *Hearing assistance systems* can provide improved auditory access in many challenging acoustic situations where hearing aids alone are of limited benefit. The intent of this standard is to ensure that where such systems are installed, they are safe and effective.

### 2.10.2 Related Sections

- (a) 2.1 Accessible Path of Travel
- (b) 2.8 Signage
- (c) 2.9 Controls

### 2.10.3 Application

- 2.10.3.1 Where practicable, this standard shall apply in exterior public spaces:
- (a) with challenging acoustic characteristics like fairgrounds and arenas;
  - (b) where key information is broadcast to provide information for safety;
  - (c) that require audible messages to engage with them such as audible pedestrian signals.

### 2.10.4 Design

- 2.10.4.1 Design requirements vary according to the setting and technology selected. Follow manufacturer's recommendations for site selection and installation.
- 2.10.4.2 Loop systems must be trenched in or otherwise secured to prevent tripping hazards.

- 2.10.4.3 System to be sited and designed to mitigate interference from nearby loops, metal buildings, powerlines and other sources of electromagnetic radiation.
- 2.10.4.4 Where hearing assistance systems are provided, they shall be accompanied by signs indicating the presence of the system, its type, and where to obtain further information.

## **2.11. LIGHTING**

### 2.11.1 Intent

2.11.1.1 This standard identifies appropriate *illumination* levels for exterior accessible paths of travel and other exterior public facilities, facilitating safe and comfortable wayfinding at night. Lighting design needs to be context specific, as the interactions between the forms, materials and uses are strong determinants of the *illumination* requirements. Balance is also important: as *illumination* levels increase, so does the risk of glare and uneven coverage, which diminish accessibility. Finally, when implemented in accordance with the principles of Crime Prevention Through Environmental Design (CPTED), lighting is key to creating a sense of personal security, which is of particularly value to vulnerable populations.

### 2.11.2 Related Sections

- (a) 2.1 Accessible path of travel
- (b) 2.7 Exterior Parking and loading zones
- (c) 2.8 Signage

### 2.11.3 Application

2.11.3.1 Applies to all entrances, routes through parking areas, and outdoor amenities and *accessible exterior paths of travel* with moderate to high nighttime pedestrian activity.

2.11.3.2 Wilderness trails are excluded. Depending on hours of operation and programming, beach access routes and docks may benefit from being illuminated, but it is not compulsory.

### 2.11.4 Design

2.11.4.1 Lighting shall comply with the 'Illuminating Engineering Society of North America' Standards.

- 2.11.4.2 Provide good colour rendering. *Colour Rendering Index* shall be greater than or equal to 84.
- 2.11.4.3 Provide even *light distribution* minimizing cast shadows.
- 2.11.4.4 Illuminate both the surface of the exterior accessible path of travel and pedestrians themselves.
- 2.11.4.5 For applicable exterior accessible paths of travel, stairs, and ramps, provide a minimum *illumination* level of 5 lux uniformly over the route, measured at ground level.
- 2.11.4.6 For stairs and ramps, provide a minimum illumination level of 50 lux measured at ground level. On stairs, locate lighting to clearly define the treads, risers, and nosings.
- 2.11.4.7 For applicable accessible parking areas, provide a minimum illumination level of 5 lux for exterior parking lots and 10 lux for parking garages, distributed uniformly, measured at ground level.
- 2.11.4.8 At applicable passenger drop off areas, provide a minimum illumination level of 30 lux, distributed uniformly over the drop off area, measured at ground level.
- 2.11.4.9 Where the exterior accessible path of travel is a sidewalk or multi-use pathway no more than 5.0m from the edge of the travelled way, it shall be designed according to the TAC Guide for the Design of Roadway Lighting, Chapter 16.

**Design Note:**

On streets, pedestrian lighting is typically installed in the furnishing zone or the frontage zone of the streetscape. When constructed in the furnishing zone, lighting contributes to the effective buffer between the sidewalk and the street, helping to define the bounds of the pedestrian area.

- 2.11.4.10 Supplementary lighting shall be provided to highlight key signage and orientation landmarks.

## **2.12. COUNTERS, TABLES AND SERVICE DESKS**

### **2.12.1 Intent**

- 2.12.1.1 To ensure that where tables and service counters are provided within the exterior public realm, those surfaces are functional, accessible, and safely integrated into the design.

## 2.12.2 Related Sections

- (a) 2.1 Accessible Path of Travel
- (b) 2.13 Benches and Seating

## 2.12.3 Application

2.12.3.1 This standard applies to exterior service spaces, such as information kiosks, serving windows, and booths, where a service counter is provided, and publicly accessible tables including, but not limited to parks, restaurant patios, courtyards, plazas and streetscapes.

## 2.12.4 Design

2.12.4.1 Tables and service counters adjacent to an accessible path of travel shall meet the following requirements:

- (a) a minimum of 20 per cent of the tables that are provided must be accessible,
- (b) not be fewer than one table in an outdoor public use eating area must be accessible;
- (c) the accessible tables spaces must have an underside clearance of:
  - (i) not less than 760mm wide,
  - (ii) not less than 685mm high,
  - (iii) not less than 485mm deep,
- (d) the accessible portion of a table surface or counter shall have:
  - (i) a maximum height is 920mm above the adjacent ground surface,
  - (ii) a minimum width of 920mm;
- (e) be clearly identified with signage where there are multiple queuing lines and service counters;
- (f) each service counter must accommodate a mobility aid, where a single queuing line serves a single or multiple counter; and
- (g) have no sharp or abrasive surfaces under the exposed accessible portions of the table or counter.

2.12.4.2 Where a picnic table is provided, it shall be in conformance with the requirements of CSA BA651.

**Question: Are the counters, tables and service desks requirements presented sufficient to meet the needs of people disabled by barriers? Are there additional requirements that should be considered to improve the standard?**

## **2.13. BENCHES AND SEATING**

### 2.13.1 2.13.1 Intent

2.13.1.1 To ensure that seating areas within the exterior public realm are inclusive and address the spatial, sensory, and social needs of people with disabilities.

### 2.13.2 Related Sections

(a) 2.1 Accessible Path of Travel

(b) 2.12 Counters, Tables and Service desks

### 2.13.3 Application

2.13.3.1 This standard applies to all seating areas within publicly accessible exterior spaces, including, but not limited to parks, restaurant patios, courtyards, plazas and streetscapes.

### 2.13.4 Design

2.13.4.1 Where a bench or seating is provided, it shall

(a) conform with CSA B651; and

(b) have the adjacent level area separated by a raised curb or barrier from any downward slope that is potentially hazardous.

#### Design Note:

(1) Benches or seats should be set back from the accessible exterior path of travel.

(2) The level area adjacent to the seat may accommodate a user with a wheelchair, a service animal, stroller, walker, etc.

(3) The ground or floor surface of the seating area should contrast in colour and texture with the surrounding surface to help people locate it.

## **2.14. WASHROOMS**

### 2.14.1 Intent

- 2.14.1.1 The intent of this section to provide equal accessibility and dignity for all people to washroom facilities, when provided in public spaces.
- 2.14.2 Related Sections
  - (a) 2.1 Accessible Path of Travel
- 2.14.3 Application
  - 2.14.3.1 The requirements for permanent outdoor washrooms apply to all exterior public spaces including, but not limited to wilderness trails, backcountry trails and portage routes where there is an accessible path of travel to access the washroom.
  - 2.14.3.2 The requirements of this section applies to all single-stall permanent outdoor washrooms.
- 2.14.4 Exceptions
  - 2.14.4.1 A washroom may not be provided where:
    - (a) The site conditions indicate that the design and construction of a permanent outdoor washroom is not practicable / reasonably doable due to terrain,
    - (b) The site conditions will require construction processes that cannot be accomplished with the prevailing construction practices and require the use of construction equipment or methods other than those typically used in a particular type of setting,
    - (c) The design and/or construction would fundamentally alter the function or purpose of the surrounding setting, OR
    - (d) The design and/or use is limited or precluded by other Federal, Provincial, or municipal law, with the intended purpose of which is to preserve threatened or endangered species; the environment; or archaeological, cultural, historical, or other significant natural features.
- 2.14.5 Design
  - 2.14.5.1 Where a permanent outdoor washroom is provided, at least one shall:
    - (a) located adjacent or connected to an accessible route; and
    - (b) have a level access from the washroom entry door to the accessible route;



- 2.14.5.2 If the permanent outdoor washroom facilities and or drinking fountains are provided, it shall be installed in conformance with the universal washroom requirements of the currently adopted *MBC*.
- 2.14.5.3 Signs incorporating the international symbol of accessibility shall be installed in prominent locations to indicate the location of barrier free facilities.
- 2.14.5.4 Directional signs shall be installed in conformance with the accessibility sign requirements of the currently adopted *MBC*.
- 2.14.5.5 Where temporary washroom facilities are provided at least one will be accessible and be on an accessible path of travel.

## **2.15. PLAY AREAS**

### **2.15.1 Intent**

2.15.1.1 Creating accessible play areas allows children of all abilities to play, socialize and interact with each other in a safe and equitable space. Play areas are integral components of community and are gathering places where children, parents and neighbours meet.

2.15.1.2 There are many different types of disabilities that affect children in Manitoba. Some of which include hearing, sight, mobility, dexterity, learning, developmental, among others. The key to the design of play spaces for all is to remove barriers that affect a child's ability to participate, grow and learn from the play opportunities provided.

2.15.1.3 Creating accessible play areas is more than simply providing a ramp to play component. It is creating spaces in which children, with their own unique circumstances, can learn to interact in the world. The design of the play area must take into account providing the following types of play experiences:

(a) Physical (develops coordination, balance, strength);

(b) Social/ cooperative (learn to interact with others);

(c) Imaginative (able to explore new ideas, thoughts, roles and concepts);

(d) Sensory (use and growth of taste, sight, smell, hearing, touch, vestibular and proprioception senses)

2.15.1.4 When considering different kinds of play experiences traditional steel and plastic play equipment is only one method of creating

these experiences. Natural play areas also create these experiences through use of berms, logs, boulders, plant material, different surfacings, etc.

## 2.15.2 Related Sections

- (a) 2.1 Accessible path of travel
- (b) 2.2 Ramps
- (c) 2.7 Exterior Parking and Loading Zones
- (d) 2.8 Signage
- (e) 2.11 Lighting
- (f) 2.13 Benches and Seating
- (g) 2.14 Washrooms

## 2.15.3 Resources

- (a) CAN/CSA-Z614 Annex H: Children's play spaces and equipment that are accessible to persons with disabilities.
- (b) ASTM F1951: Standard Specification for Determination of Accessibility of Surface Systems Under and Around Playground Equipment.
- (c) ASTM F1292: Standard Specification for Impact Attenuation of Surfacing Materials Within the Use Zone of Playground Equipment.

## 2.15.4 Application

- 2.15.4.1 The requirements for play areas shall apply to all publicly available play areas; new construction as well as renovations and significant expansions of existing play areas. Play areas shall be accessible to the broadest range of people possible.

## 2.15.5 Design

- 2.15.5.1 Play areas shall conform with CAN/CSA-Z614 Annex H: *Children's play spaces and equipment that are accessible to persons with disabilities.*
- 2.15.5.2 Play areas shall be connected to the street, parking area, or sidewalk by an accessible path of travel.
- 2.15.5.3 Other amenities within the outdoor environment, such as washrooms, picnic areas, etc. shall be connected to the play area by an accessible path of travel.

- 2.15.5.4 Seating near the play area shall comply with section 2.13 Benches and Seating.
- 2.15.5.5 The ground level within the play space itself shall have an accessible route which connects the various ground level and elevated play components together. This accessible route shall have:
- (a) minimum 1200mm width as long as there is at least one 1500mm diameter turning space available;
  - (b) minimum 2030mm in vertical clearance;
  - (c) Maximum running slope of 1:20;
  - (d) Maximum cross slope of 1:50;
  - (e) surfacing that meets the requirement of ASTM F1951: *Standard Specification for Determination of Accessibility of Surface Systems Under and Around Playground Equipment.*
    - (i) If the accessible route is within the fall zone of play equipment the surfacing must also meet the requirements of ASTM F1292: *Standard Specification for Impact Attenuation of Surfacing Materials Within the Use Zone of Playground Equipment.*

Design Note:

SURFACING: The primary means of creating an accessible play spaces is to utilize accessible surfacing. Engineered wood fibre (a loose fill surfacing) is currently considered an accessible surface but is quite difficult to wheel on for wheelchair users and those with mobility issues. Unitary surfacing (such as poured-in-place rubber) provides a much more user-friendly means of access for all users.

- 2.15.5.6 As per section 2.2 Ramps, all routes with a slope greater than 1:20 shall be considered a ramp.
- 2.15.5.7 To meet the needs of people with restricted mobility, design all play elements from the perspective of a wheelchair user, and consider the following measures:
- (a) Keep paths short
  - (b) The area around the play areas should be easily walkable and wheelchair accessible
  - (c) Provide additional climbing facilities, hand holds and supporting equipment

Design Note:

DEFINITIONS:

- (1) Composite play structure is playground equipment that is attached through elevated decks, climbers or ground level pods to create one integrated play unit.
- (2) A play component is an event within a play area that can be used for play, learning, socializing, etc. Decks, ramps, transfer systems and stairs are not considered play components but means of access to them.
- (3) Transfer systems are platforms located at a certain height above the ground in which people in wheelchairs can transfer from their wheelchair to the play structure or play component.
- (4) Elevated deck is a portion of a composite play structure in which there are level surfaces above grade. These level surfaces (decks) can be accessed by stairs, ramps, or climbers.
- (5) Elevated play components are play components that in order to fully use the component, must be accessed off elevated decks in a composite play structure, examples include climbers that lead from an elevated deck to the ground surface, slides, or fireman poles.
- (6) Ground level play components are those that can be utilized off the ground level, such as spring riders, play panels at grade, etc.

2.15.5.8 CAN/CSA-Z614 Annex H provides a table indicating the minimum required number of ground level play components when a composite play structure with elevated play components is provided (see Table 2 below). This ensures that when someone is not able to climb the stairs or climbers to reach the decks of the structure there are still play activities that can be used within the play area.

- (a) Ground level play components as indicated in Table 2 is not a requirement though when at minimum 50% of the elevated play components are connected by ramp, and when these play components are at minimum three different types.

- (b) If twenty (20) or more elevated play components are provided, ramped access to a minimum of 25% of the elevated play components is required.
- (c) If less than twenty (20) elevated play components are provided, a ramp or transfer system access must be provided to a minimum of 50% of the elevated play components.

2.15.5.9 Providing one ramp on at least a segment of all play structures should be considered. Transfer stations are helpful but still eliminate the play structure use by anyone who cannot transfer out of their mobility device.

<b>Number of Elevated Play Components</b>	<b>Min. Number of Ground-Level Play Components Required on Accessible Route</b>	<b>Min. Number of Different Types of Ground-Level Play Components on Accessible Route</b>
1	Not Applicable	Not Applicable
2 to 4	1	1
5 to 7	2	2
8 to 10	3	3
11 to 13	4	3
14 to 16	5	3
17 to 19	6	3
20 to 22	7	4
23 to 25	8	4
More than 25	8 plus 1 for each additional 3 over 25, or fraction thereof	5

Table 2: Minimum Number and Types of Ground Level Play Components on Accessible Route

2.15.5.10 Not only is physical access important, but incorporating components that provide movement, touch, sound, and visual stimulation are critical to cognitive skills development and inclusion. Play areas for all must include at least one integrative play facility for visually and/or hearing impaired children and children with physical or sensory disabilities that is compliant with their respective safety needs.

2.15.5.11 For safety of all users, play areas shall be sited in areas that include shade or allow for the provision of shade through new plantings or other means.

Play areas shall be separated from hazards such as traffic areas or steep grade changes by physical barriers.

**Design Note:**

Some children have a propensity to run when they feel stressed or uncomfortable. A fully fenced play area adds an extra level of security for children and parents.

**Design Note:**

A tactile orientation map at the entrance of the play area should be provided. In addition, changes in level within play areas should have a contrasting colour strip to demarcate the leading edge of the tread or the nosing, as per section 2.3 Stairs.

**Question: Are the play area requirements presented sufficient to meet the needs of people disabled by barriers? Are there additional requirements that should be considered to improve the standard?**

## 2.16. SPORTS FACILITIES

### 2.16.1 Intent

2.16.1.1 Creating accessible sports facilities allows people of all abilities to play, socialize and interact with each other in a safe and equitable space. Sports facilities are integral components of community and are gathering places where people of all ages and abilities meet. A significant component of the use and enjoyment of sports facilities is the provision of areas for spectators. Ensuring access to both the functional and experiential components of the public realm is a priority that must be addressed in a manner that provides equal access while maintaining the contextual integrity of the spaces being considered.

### 2.16.2 Related Sections

- (a) 2.1 Accessible Path of Travel
- (b) 2.2 Ramps

- (c) 2.3 Stairs
- (d) 2.4 Mechanical lifts
- (e) 2.7 Exterior parking and loading zones
- (f) 2.8 Signage
- (g) 2.14 Lighting
- (h) 2.13 Benches and Seating
- (i) 2.14 Washrooms
- (j) 2.15 Play areas
- (k) 2.17 Docks and Boat launches

### 2.16.3 Application

- 2.16.3.1 The requirements for Sports Facilities pertain to all publicly available purpose-built sports facilities including, but not limited to:
- (a) Field sports (For example: soccer, football, baseball, lacrosse)
  - (b) Ice sports (For example: hockey, curling, figure skating)
  - (c) Court Sports (For example: tennis, basketball)
  - (d) Specialized facilities (For example: Bike Trails, Skateboard Parks, Golf Courses)

### 2.16.4 Exceptions

- 2.16.4.1 The requirements for sports facilities will apply except where:
- (a) The site conditions indicate that the design and construction of an accessible sport facility is not practicable / reasonably doable due to terrain.
  - (b) The design and/or construction would fundamentally alter the function or purpose of the surrounding setting.

### 2.16.5 Design

- 2.16.5.1 The accessible paths of travel standard applies to the access between each Area of Sport Activity.
- 2.16.5.2 The Area of Sport Activity is exempt from requirements pertaining to surfacing, ramps, slopes, protrusions, as they must be designed and constructed to the requirements specific to each sport activity.
- 2.16.5.3 The requirements for Sports Facilities will apply to ensuring that areas for spectators as it relates to the Area of Sport Activity follow

the accessible paths of travel standard and maximize visibility for observation.

- 2.16.5.4 Where a governing body does not exist for a sport activity, every effort must be made to consult with the active users to ensure that the active and passive uses for the sport activity maximize access and safety.

## **2.17. DOCKS / BOAT LAUNCHES**

### 2.17.1 Intent

- 2.17.1.1 Creating accessible docks and boat launches ensures a general level of usability for individuals with disabilities to access the boating facility and use a variety of elements. Designers are encouraged to exceed the guidelines where possible to maximize accessibility while maintaining safety. Ensuring access to both the functional and experiential components of the public realm is a priority that must be addressed in a manner that provides equal access while maintaining the contextual integrity of the spaces being considered.

### 2.17.2 Related Sections

- (a) 2.1 Accessible Path of Travel
- (b) 2.2 Ramps
- (c) 2.3 Stairs
- (d) 2.4 Mechanical lifts
- (e) 2.7 Exterior parking and loading zones
- (f) 2.8 Signage
- (g) 2.14 Lighting
- (h) 2.13 Benches and Seating
- (i) 2.14 Washrooms
- (j) 2.16 Sports Facilities

### 2.17.3 Application

- 2.17.3.1 The requirements for docks and boat launches will apply to all publicly available docks and boat launches suitable for all watercraft including, but not limited to: canoes, kayaks, sailboats, and motorized boats.



## 2.17.4 Exceptions

2.17.4.1 The requirements for docks and boat launches will apply except where:

- (a) The site conditions indicate that the design and construction of an accessible dock or boat launch is not practicable / reasonably doable due to terrain.
- (b) The design and/or construction would fundamentally alter the function or purpose of the surrounding setting.
- (c) The design and/or use is limited or precluded by other Federal, Provincial, or municipal law, with the intended purpose of which is to preserve threatened or endangered species; the environment; or archaeological, cultural, historical, or other significant natural features.
- (d) The development is related to passenger vessels and/or ferry docks.

## 2.17.5 Design

2.17.5.1 Service to the active components of docks and active boat launch areas must adhere to accessible paths of travel standard. At least one accessible path of travel must be provided to the active components of docks and boat launch areas.

2.17.5.2 An exterior accessible path of travel must have a minimum 2,500 mm headroom clearance height.

2.17.5.3 *Gangways* are considered part of accessible paths of travel and must conform with accessible route requirements during normal water level conditions.

**Design Note:**

As water levels rise and fall, *gangway* slopes also rise and fall. Seasonal variation of water level may limit boat access due to flooding or low water conditions.

2.17.5.4 As a minimum, *gangways* must have a maximum slope of 1:12 but are not required to be longer than 24m. Therefore, at times, the *gangway* slope may be less than 1:20 and at other times it may be more than 1:12.

- 2.17.5.5 In smaller facilities, with less than 25 *boat slips*, the slope of the *gangway* may exceed 1:12 if the *gangway* is at least 9m long.<sup>1</sup>
- 2.17.5.6 Where *gangways* connect to transition plates, the condition at transition plates does not need to meet the requirements for landings, or handrails for accessible paths of travel, or ramps if the slope is 1:20 or less across the transition plate. If the slope on the transition plate is greater than 1:20, the transition plate must have a landing at the non-*gangway* end of the plate and conform with other ramp requirements
- 2.17.5.7 Cross slope of *gangways*, transition plates, and floating piers must be 1:50 maximum measured in static position.
- 2.17.5.8 The surface for docks must adhere to the standard for accessible paths of travel (i.e. decking)
- 2.17.5.9 Edge protection as per accessible paths of travel along pier must be provided.
- 2.17.5.10 Where *boat slips* are provided, accessible *boat slips* must be provided at a quantity of 1 accessible *boat slip* minimum per 25 slips (a minimum of one accessible *boat slip* to be provided if less than 25 slips). Where *boat slips* are not identified, every 1200mm of *boat slip* edge along perimeter of pier equals one boat slip
- 2.17.6 At least 1500mm minimum clear pier space must be provided, for the length of the *boat slip*, per accessible *boat slip*.
  - (a) 1500mm minimum width openings must be provided at an interval of 3000mm along the pier edge(s) where boats are permitted to dock. The pier edge available for docking must contain a minimum of one continuous width of opening of 1500mm minimum.

## **2.18. BEACH ROUTES AND RECREATIONAL TRAILS**

- 2.18.1 Intent
- 2.18.2 Beaches and recreational trails should be able to be enjoyed by all Manitobans if they so wish. Ensuring access to these amenities while maintaining the integrity of the natural surrounding is essential.
- 2.18.3 Related Sections

- (a) 2.1 Accessible Path of Travel
- (b) 2.2 Ramps
- (c) 2.3 Stairs
- (d) 2.4 Mechanical lifts
- (e) 2.7 Exterior parking and loading zones
- (f) 2.8 Signage
- (g) 2.14 Washrooms

#### 2.18.4 Application

2.18.4.1 When there is an accessible path of travel to the beach, a beach route shall be provided to the water's edge.

2.18.4.2 Recreational trails shall follow the minimum requirements of section 2.1 Accessible Path of Travel other than a case that falls into one or more of the exceptions below.

#### 2.18.5 Exceptions

2.18.5.1 Where the site conditions indicate that the design and construction of an accessible path of travel is not practicable due to natural terrain;

2.18.5.2 Where the site conditions will require construction processes that cannot be accomplished with the prevailing construction practices and require the use of construction equipment or methods other than those typically used in a particular type of setting;

2.18.5.3 Where the design and/or construction would fundamentally alter the function or purpose of the surrounding setting; OR

2.18.5.4 Where the design and/or use is limited or precluded by other Federal, Provincial, or municipal law, with the intended purpose of which is to preserve threatened or endangered species; the environment; or archaeological, cultural, historical, or other significant natural features.

#### 2.18.6 Design

2.18.6.1 As per the accessible path of travel.

**Design Note:**

Some examples of means of providing a beach route could include use of a boardwalk, access mats or beach wheelchairs.

Design Note:

Trailhead signs for recreational trails provide valuable information on where the route is located. In order to improve usability of the trail for all users it is recommended to add the following information either on the trailhead itself, on the park website or a separate brochure:

- a) The length of the trail.
- b) The type of surface of which the trail is constructed.
- c) The average and the minimum trail width.
- d) The average and maximum running slope and *cross slope*.
- e) The location of amenities, where provided.

Design Notes:

People using primitive trails experience the outdoor environment in a nearly natural state, with limited or no development. Use of manufactured building materials or engineered construction techniques to comply with specific provisions in the technical requirements for trails could fundamentally alter the natural or undeveloped nature of the setting and change the recreational experience. Trails that are intended to provide a rugged experience, such as a cross-country training trail with a steep grade, a fitness challenge course with abrupt and severe changes in elevation, and a trail that traverses boulders and rock outcroppings to provide users with the opportunity to climb the rocks, are other examples. To remove the obstacles on these trails or to reroute the trails around the obstacles would fundamentally alter the function or purpose of the trails. (USAB – Outdoor Developed Areas)

For example, where a trail is constructed in a steeply sloped area, compliance with the running slope provision may not be practicable on parts of the trail where it would require extensive cuts or fills that are difficult to construct and maintain, cause drainage and erosion problems, significantly lengthen the trail, and create other adverse environmental impacts. (USAB – Outdoor Developed Areas)

For example, where hand tools would normally be used to construct a trail in order to minimize the impact on a sensitive

adjacent stream and the prevailing construction practices for this type of setting do not include blasting, blasting does not have to be used to remove a rock outcrop in order to comply with the clear tread width provision. Compliance with the clear tread width provision is required to the extent that it can be accomplished using hand tools.

## **SECTION 3      OPERATIONS**

### **3.1.      MAINTENANCE**

#### 3.1.1      Intent

3.1.1.1    All organizations subject to this standard will be responsible for the maintenance of the accessible path of travel and associated elements. An organization's policies, practices and procedures must address all operations that will ensure the path of travel is accessible at all times.

#### 3.1.2      Content of Maintenance Plan

3.1.2.1    An organization's procedures regarding maintenance must include the following:

(a) Procedures for preventative and emergency maintenance of the accessible elements in public spaces as required.

(b) Procedures for dealing with temporary disruptions when accessible elements are not in working order.

(c) Snow clearing to ensure accessible path of travel is clear of snow as per section 3.2 Snow Clearing.

#### 3.1.3      Application

3.1.3.1    An organization's policies, practices and procedures regarding maintenance is to be provided to all personnel responsible for maintaining the accessible path of travel. This includes maintenance staff, contractors, managers and designers to ensure the plans for maintenance are understood and followed.

### **3.2.      SNOW CLEARING**

#### 3.2.1      Intent

3.2.1.1    Snow removal and ice control on publicly accessible paths of travel need to be maintained to a level that allows access for all users regardless of age, size, ability and disability. Manitobans in all communities rely on sidewalks that are cleared of snow and maintain an expectation that travel can be done so safely and efficiently.

#### 3.2.2      Application

3.2.2.1    This standard will require all jurisdictions to follow the below when creating their snow and ice control plans:

- (a) Ensure that ALL publicly accessible paths of travel and public properties are maintained to a level that allows all users to mobilize and access their communities.
- (b) Review and update their snow and ice control policies and/or procedures to reflect the needs of the community.
- (c) Consult with community groups on an annual basis to ensure that the policies are working toward continuous improvement and the goal of being a barrier free community to the greatest extent possible.

### 3.2.3 Rationale

3.2.3.1 Public consultations have gathered strong public opinion that snow and ice is the one of largest and most difficult barriers to overcome when you live with a disability and for the aging population. It is incumbent upon every municipality to review their policies and/or procedures to ensure our communities are barrier free to the greatest extent possible.

**Question: Are the maintenance presented sufficient to meet the needs of people disabled by barriers? Are there additional requirements that should be considered to improve the standard?**

## **APPENDIX 1**

### **Reference Material for the Design of Public Spaces Committee**

1. Ontario Design of Public Spaces Accessibility Standard
2. Manitoba Building Code (2010)
3. National Building Code (2015)
4. Canadian Standards Association (CSA) B651-18
5. United States Access Board - Outdoor Developed Areas
6. United States Access Board – Accessible Boating Facilities
7. United States Access Board – Public Right-of-Way Accessibility Guidelines
8. American National Standards Institute (ANSI) ICC-A117.1 Accessible and Usable Buildings and Facilities
9. City of Winnipeg Accessibility Design Standards (2015)
10. Berlin – Design for All – Public Outdoor Space
11. International Standard Organization (ISO) 21542: 2011 Building Construction – Accessibility and Usability of Built Environment
12. Canadian National Institute for the Blind (CNIB) Clearing our Paths (2016)
13. Transportation Association of Canada (TAC) Geometric Design Guide for Canadian Roads - Chapter 5 – Bicycle Integrated Design (2017)
14. Transportation Association of Canada (TAC) Geometric Design Guide for Canadian Roads – Chapter 6 – Pedestrian Integrated Design
15. A Guide to Accessible Design for Designers, Builders, Facility Owners and Managers, 3<sup>rd</sup> Edition, 2000
16. Illuminating Engineering Society of North America Standards
17. Crime Prevention Through Environmental Design
18. Best Practices Guide to the Accessible Design of the National Capital Commission’s Outdoor Spaces
19. The Universal Trail Assessment Process Training Guide